Commodore Graphic Printer

Technical Manual

Model 1515/1525 Manual



 **commodore**
COMPUTER

These documents are for repair service information only. Part numbers are for reference only. Only parts on current dealer parts list are available. No license is given for any use by possession of these documents and may not be reproduced in any form without the written approval of Commodore Electronics Limited.

CONTENTS

I. SPECIFICATIONS	2
II. CONSTRUCTION	5
1. SUMMARY	5
2. PRINTING	7
3. LINEFEED	10
4. CIRCUIT	12
5. TIMING DIAGRAM	14
III. REPAIRING LEVEL	17
IV. MEASURING INSTRUMENTS AND TOOLS	17
V. MAINTENANCE	18
1. CLEANING	18
2. LUBRICATING	18
VI. DISASSEMBLY AND REASSEMBLY	19
1. UPPER CASE	19
2. LOWER CASE BLOCK AND MACHINE ASSEMBLY	20
3. LOWER CASE BLOCK	23
4. CONTROL PCB UNIT AND LAMP PCB UNIT	26
5. PRINT HEAD UNIT	27
6. LINEFEED MECHANISM	28
7. FEED DRUM AND CARRIER UNIT	29
8. GEAR TRAIN	32
9. TRACTOR	34
VII. TROUBLESHOOTING	35

I. SPECIFICATIONS

1. General Specifications

- Print method Impact dot-matrix print (SEIKOSHA's uni-hammer method)
- Print format 5 x 7 dot-matrix
- Characters upper/lower case characters, numeric symbols, & Pet graphics
- Graphics Dot addressable. 7 vertical dots per column
- Character Codes 8-bit codes (Vic-20,C-64 codes)
- Character size Height: 7 dots (2.82 mm)
Width: 5 dots (1.76 mm)
- Print Speed 30 characters/sec. (left to right, uni-directional)
- Maximum Columns 80 columns
- Character Spacing 12 characters/inch (10 characters/inch on 1525)
- Linefeed Spacing 6 lines/inch Character mode
9 lines/inch Graphic mode
- Linefeed Speed 5 lines/sec Character mode
7.5 lines/sec Graphic mode
- Paper Feed Pin feed
- Paper Width 4.5 to 8 inches acceptable (10 inches on 1525)
- Number of Copies Up to 3 copies including orig.
- Inked Ribbon Inked roller built-in cassette type, single color
- Dimensions 132 x 328 x 172.5 mm (1525; 234Dx420Wx134H)
- Weight Approx. 2.5 kg (1525; 4.2kg)

2. Environment

- Power Requirements 117 VAC±10%, 50/60 Hz for USA 50/60 Hz for Europe
- Power Consumption 15 watts max. (character printing)(1525; 20W)
5 watts (idling)(1525; 8W)
- Temperature 5°C to 40°C
- Humidity 20% to 80% (non-condensing)

3. Features and Codes

3.1 Main features

- Double width character output under software control.
- Graphics capability (picture and graph output capabilities).
- In the graphic mode, a graphic data pattern can be repeated as many times as you want with a single command.
- Print position addressable by character or dot column (positioning control).
- Graphic, character and double width character modes can be intermixed on a single line.
- Automatic printing. When the text exceeds the maximum line length no data is lost due to overflow.
- Self-test printing is available.

3.2 Printing modes

- Character mode
- Double width character mode
- Graphic mode

3.3 Control codes

- NL (0,A) Line feed after printing
- CR (0,D) Line feed or no line feed after printing (jumper selectable, see below)
- DC4 (1,4) No line feed after printing
(The above three codes are print commands)
- BS (0,8) Graphic mode command
- SO (0,E) Double width character mode command
- SI (0,F) Character mode command
- POS (1,0) Print start position addressing
- ESC (1,B) When followed by the POS code it is used to specify a start position according to the dot address
- FS (1,C) Repeat graphic select command

CURSOL UP MODE Code Table

				0	0	0	0	0	0	0	0	1	1	1	1	1	1	1	1					
				0	0	0	0	1	1	1	1	0	0	0	0	1	1	1	1					
				0	0	1	1	0	0	1	1	0	0	1	1	0	0	1	1					
				0	1	0	1	0	1	0	1	0	1	0	1	0	1	0	1					
D7	D6	D5	D4	D3	D2	D1	D0		0	1	2	3	4	5	6	7	8	9	A	B	C	D	E	F
				0	0	0	0	0	POS	SP	0	@	P	□	□			SP	□	□	□	□	SP	□
				0	0	0	1	1	CURSOR	↑	1	A	Q	▲	●		CURSOR	↑	□	□	▲	●	□	□
				0	0	1	0	2	SYS	"	2	B	R	□	□		REV	OFF	□	□	□	□	□	□
				0	0	1	1	3		#	3	C	S	□	▼			□	□	□	▼	□	□	□
				0	1	0	0	4		S	4	D	T	□	□			□	□	□	□	□	□	□
				0	1	0	1	5		%	5	E	U	□	□			□	□	□	□	□	□	□
				0	1	1	0	6		&	6	F	V	□	⊗			⊗	□	□	⊗	⊗	□	□
				0	1	1	1	7			7	G	W	□	□			□	□	□	□	□	□	□
				1	0	0	0	8	BS		(8	H	X	□	⊕			⊕	□	□	⊕	⊕	□
				1	0	0	1	9)	9	I	Y	□	□			□	□	□	□	□	□	□
				1	0	1	0	A	NL	SUB	*	:	J	Z	□	◆			□	□	□	◆	□	□
				1	0	1	1	B	ESC	+	:	K	(□	⊞			⊞	□	□	⊞	⊞	□	□
				1	1	0	0	C		.	<	L	¥	□	□			□	□	□	□	□	□	□
				1	1	0	1	D	CR		-	=	N)	□	□			□	□	□	□	□	□
				1	1	1	0	E	SO		.	>	O	↑	□	□			□	□	□	□	□	□
				1	1	1	1	F	SI		/	?	P	←	□	□			□	□	□	□	□	□

CURSOL DOWN MODE Code Table

				0	0	0	0	0	0	0	0	1	1	1	1	1	1	1	1					
				0	0	0	0	1	1	1	1	0	0	0	0	1	1	1	1					
				0	0	1	1	0	0	1	1	0	0	1	1	0	0	1	1					
				0	1	0	1	0	1	0	1	0	1	0	1	0	1	0	1					
D7	D6	D5	D4	D3	D2	D1	D0		0	1	2	3	4	5	6	7	8	9	A	B	C	D	E	F
				0	0	0	0	0	POS	SP	0	@	p	□	P			SP	□	□	P	SP	□	□
				0	0	0	1	1	CURSOR	↓	1	a	q	A	Q		CURSOR	↓	□	□	A	Q	□	□
				0	0	1	0	2	SYS	"	2	b	r	B	R		REV	OFF	□	□	B	R	□	□
				0	0	1	1	3		#	3	c	s	C	S			□	□	C	S	□	□	
				0	1	0	0	4		S	4	d	t	D	T			□	□	D	T	□	□	
				0	1	0	1	5		%	5	e	u	E	U			□	□	E	U	□	□	
				0	1	1	0	6		&	6	f	v	F	V			□	□	F	V	⊗	□	
				0	1	1	1	7			7	g	w	G	W			□	□	G	W	□	□	
				1	0	0	0	8	BS		(8	h	x	H	X			□	□	H	X	⊕	□
				1	0	0	1	9)	9	i	y	I	Y			□	□	I	Y	⊕	□	
				1	0	1	0	A	NL	SUB	*	:	j	z	J	Z			□	□	J	Z	□	□
				1	0	1	1	B	ESC	+	:	k	(K	⊞			⊞	□	□	K	⊞	⊞	□
				1	1	0	0	C		.	<	l	¥	L	□			□	□	L	□	□	□	□
				1	1	0	1	D	CR		-	=	m)	M	□			□	□	M	□	□	□
				1	1	1	0	E	SO		.	>	n	↑	N	⊞			□	□	N	⊞	□	□
				1	1	1	1	F	SI		/	?	o	←	O	⊞			□	□	O	⊞	□	□

II. CONSTRUCTION

1. SUMMARY

Figure 1 shows the block diagram and Figure 2 is a flowchart showing the sequence of its motion.

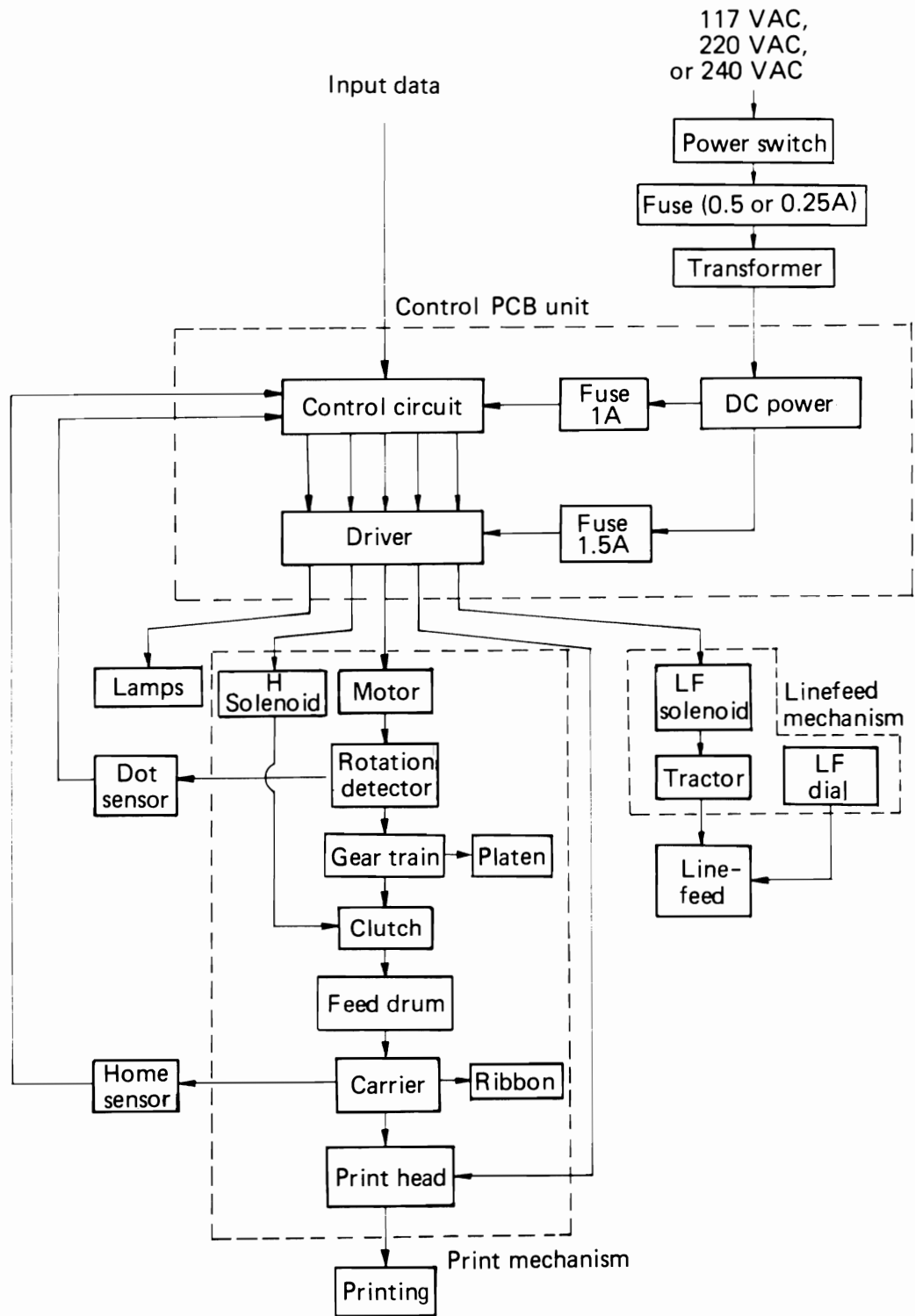

Figure 1

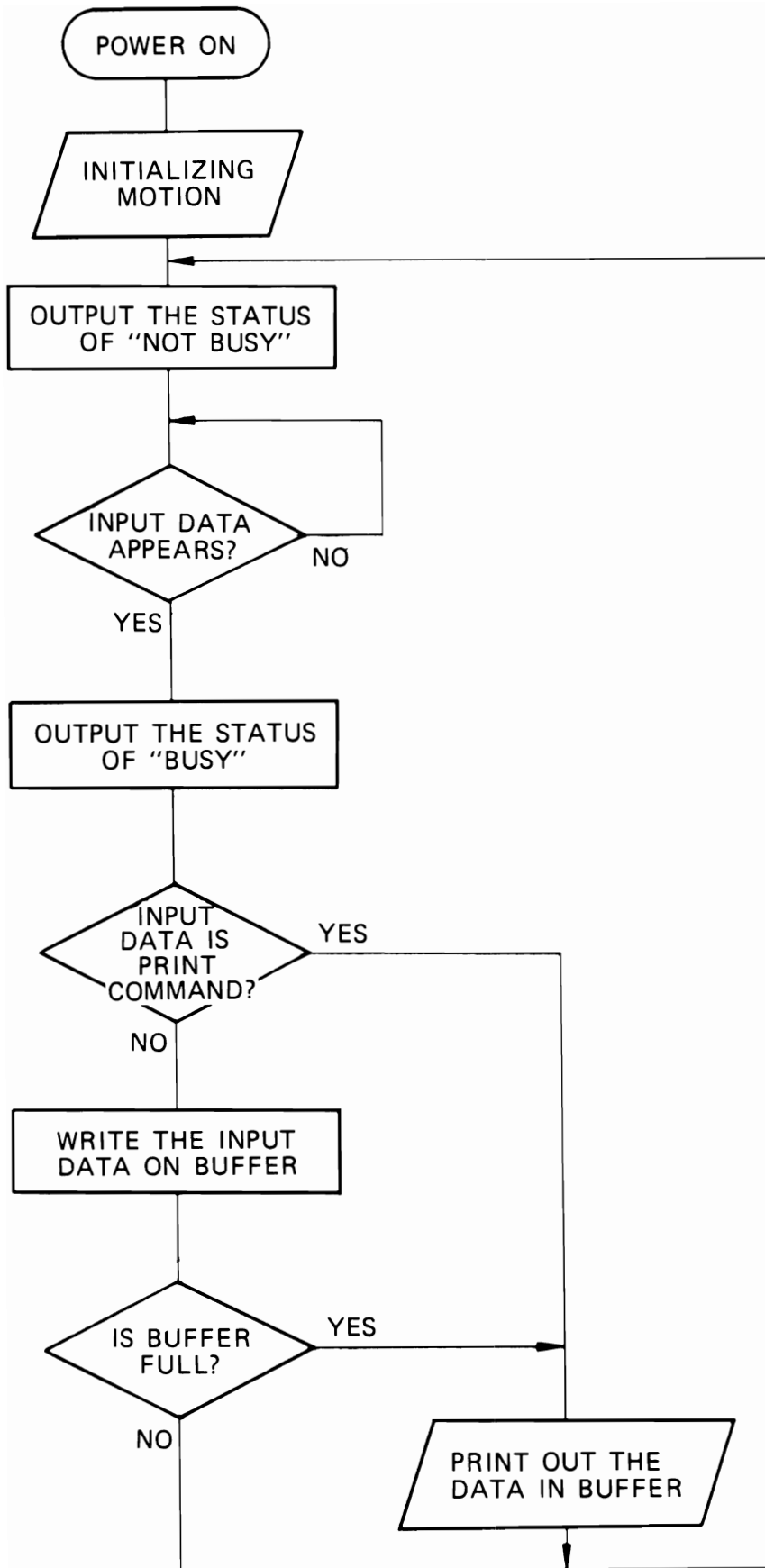

Figure 2

2. PRINTING

(1) PRINTING MECHANISM

This Printer is based on a single printing hammer system which is quite unique and different from other impact dot printing systems. The timing of hammer printing depends upon revolution of the rotation detector. This revolution, rightward movement of the hammer and the revolution of the platen are synchronized. Character and graphics dots are printed when the relative positions of the hammer head and the platen are encountered. The relationship of the hammer, the platen and the dot sensor is shown in Figure 3; that of the hammer head, printed dot, and signals of the dot sensor in Figure 4

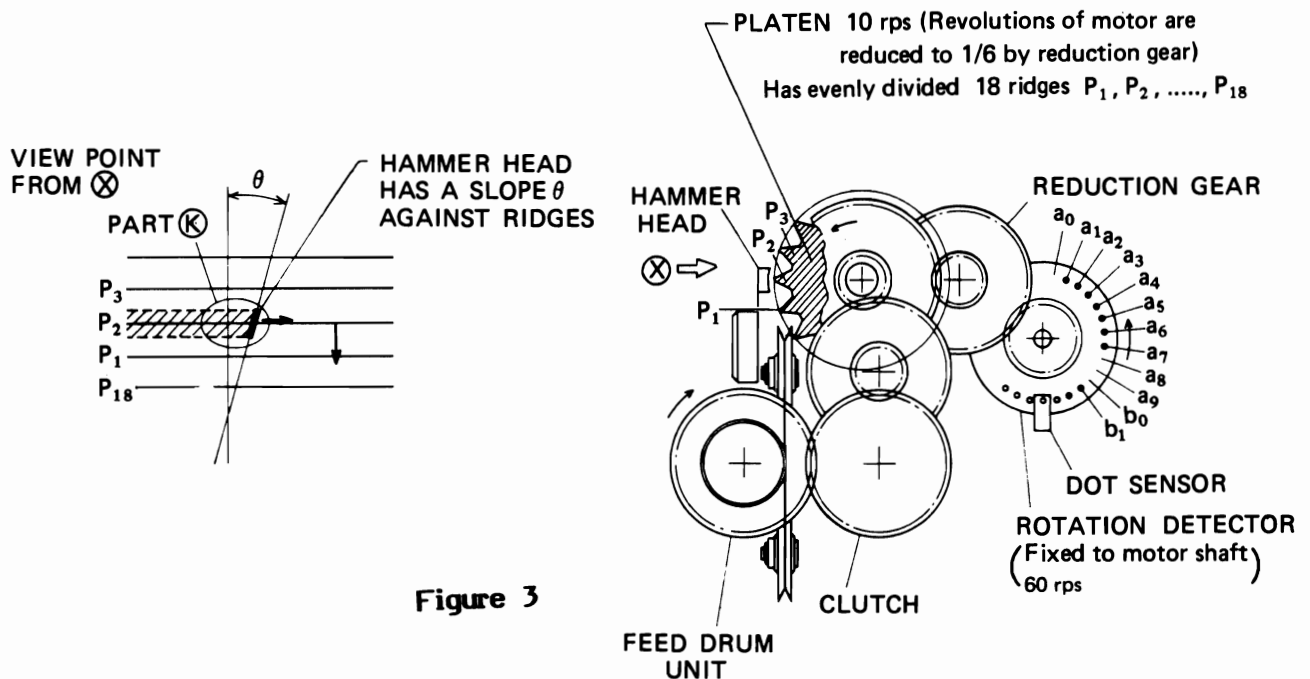

Figure 3

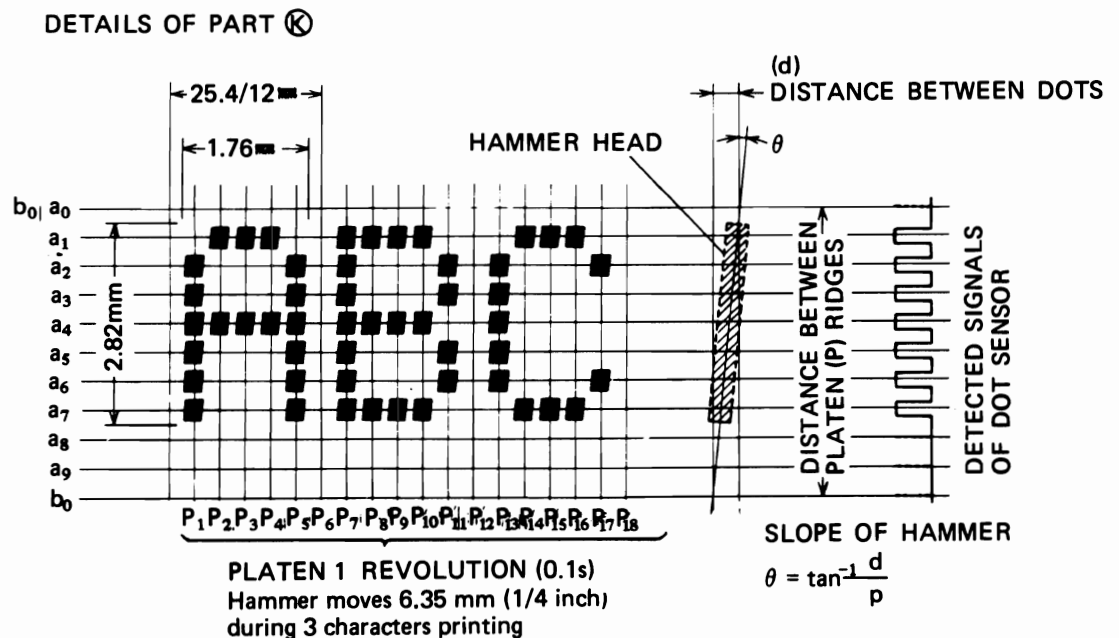
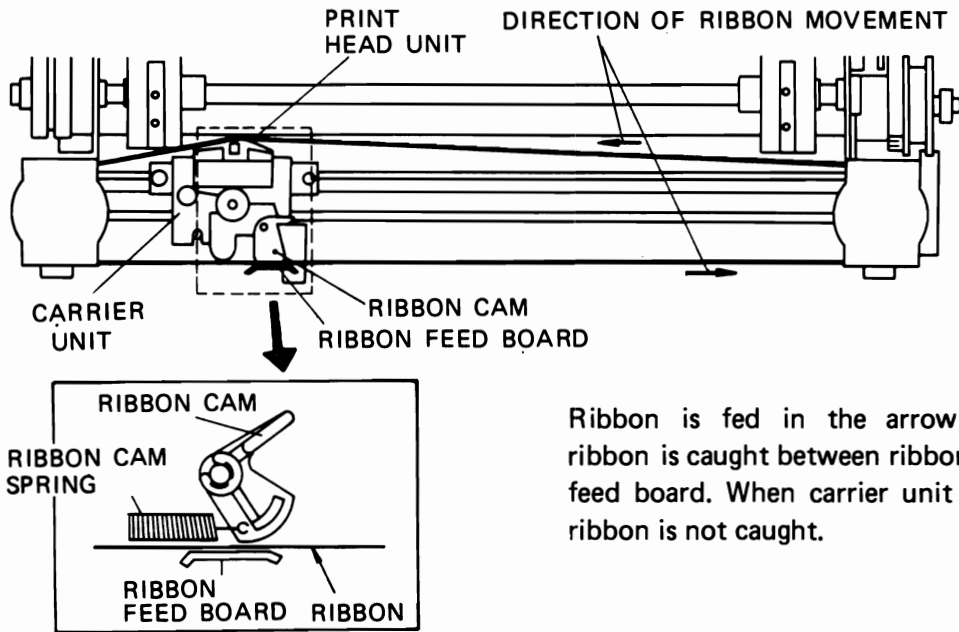

Figure 4

(2) CARRIER UNIT MOVEMENT AND RIBBON FEEDING

Figure 5 shows rightward movement of the carrier unit and ribbon feeding due to motor revolutions. Figure 6 describes the carrier unit's return to the home position, activated by the H solenoid.



Ribbon is fed in the arrow direction when ribbon is caught between ribbon cam and ribbon feed board. When carrier unit returns leftward, ribbon is not caught.

Figure 5

CONSTRUCTION OF H SOLENOID AND CLUTCH

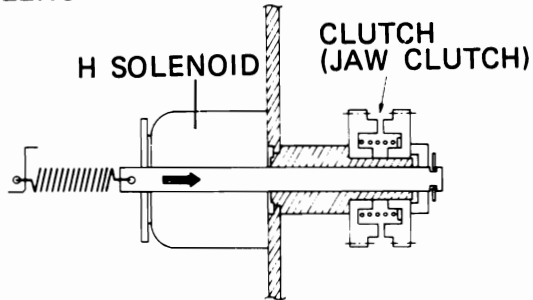

When H solenoid is pulled, the clutch is released and the carrier unit returns to the leftmost home position forced by the recovery spring.

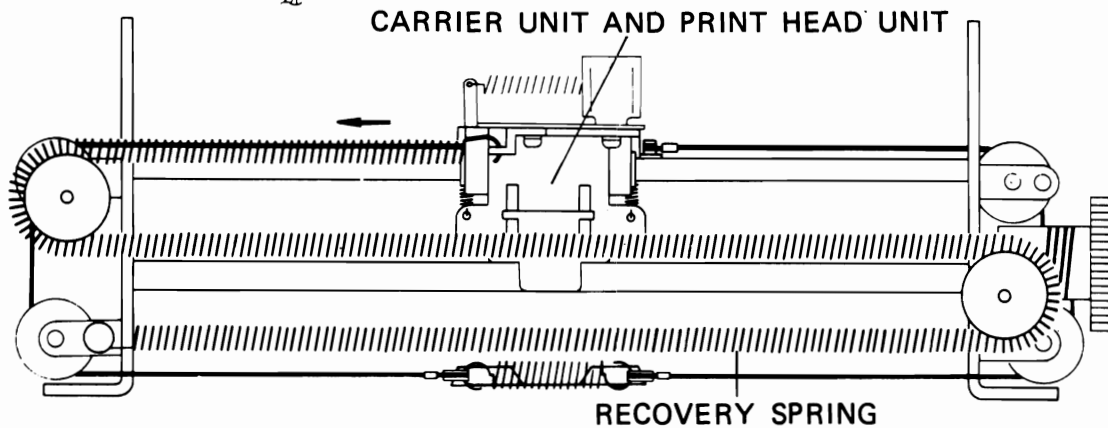
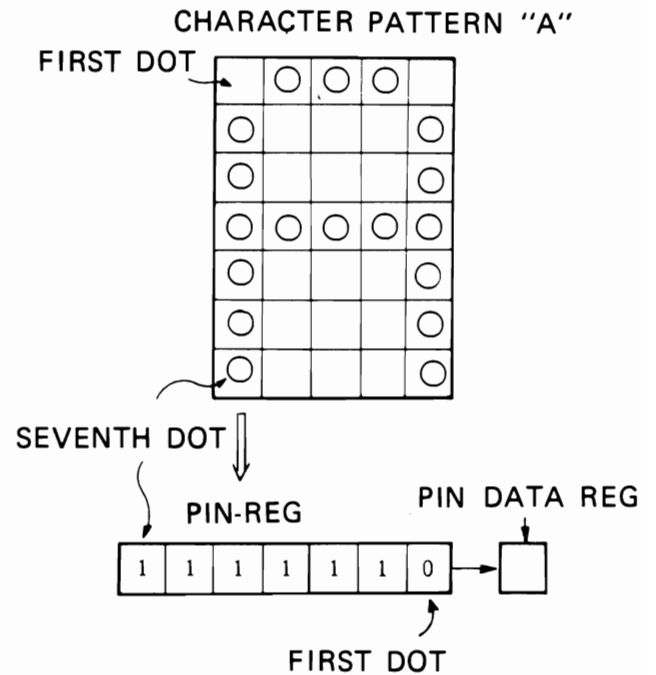
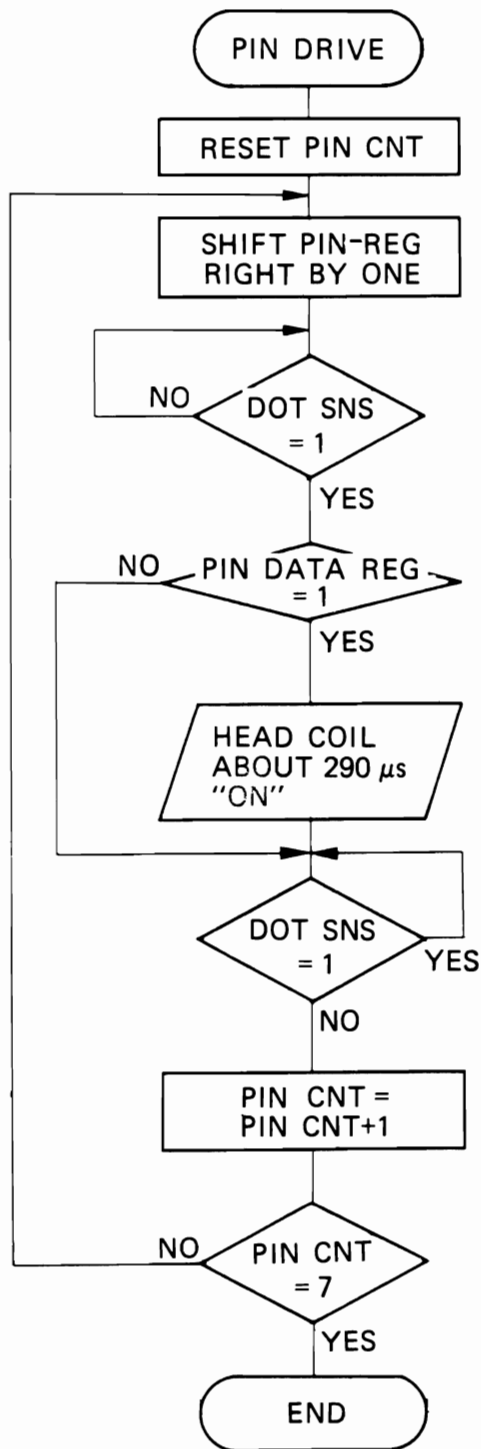

Figure 6

(3) HAMMER DRIVE (PIN DRIVE) FLOWCHART



PIN CNT: A counter for one column (7 dots) of a character pattern.
 PIN-REG: A register storing one column (7 dots) of a character pattern.
 DOT SNS: Timing signal for each dot.
 PIN DATA REG: One bit register for a dot to be printed.

Figure 7

3. LINEFEED

(1) LINEFEED MECHANISM

Figure 8 shows the linefeed (paper feed) controlled by the motion of the LF solenoid. The LF solenoid is activated three times for printing characters and two times for printing graphics.

The transmission sequence of a LF solenoid motion is:



The condition of the claw wheel unit when the LF solenoid is inactive is:

- i) The claw wheel unit is pulled by the LF rope spring.
- ii) The saw teeth of the LF claw wheel and the saw teeth which are pushed by the claw wheel spring are coupled.

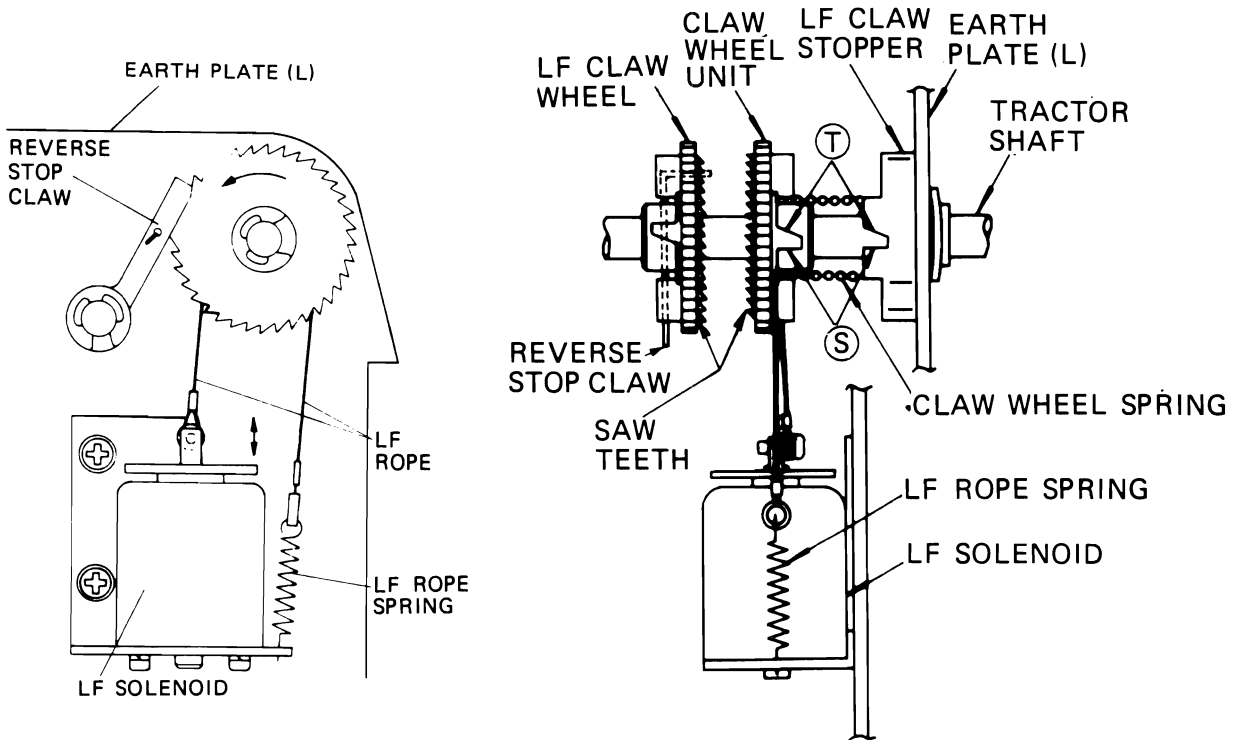

Figure 8

(2) LINEFEED FLOWCHART

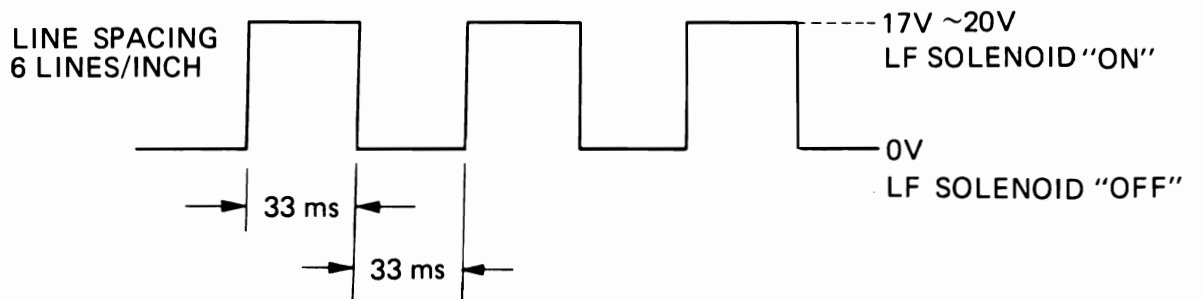
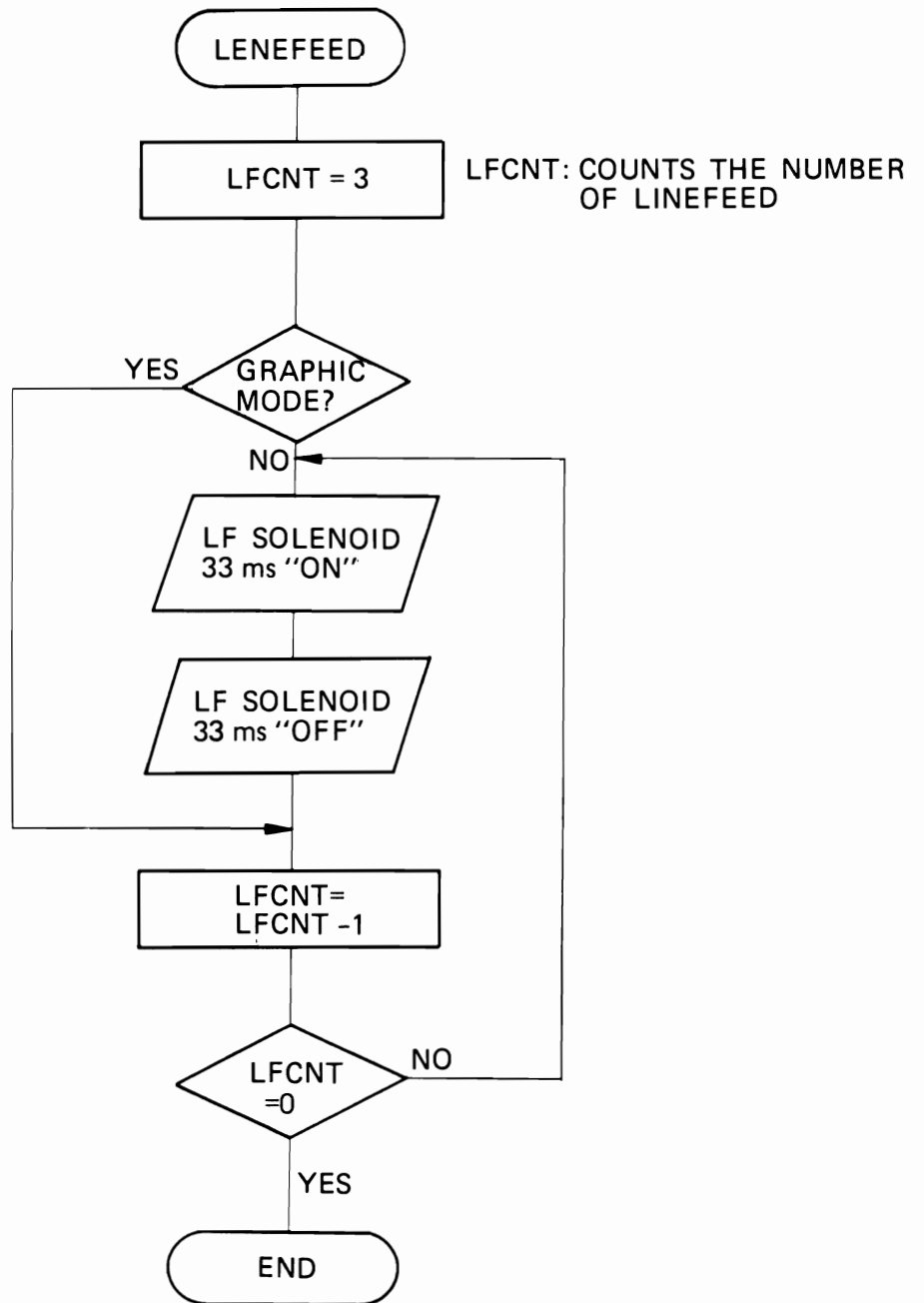

Figure 9

4. CIRCUIT

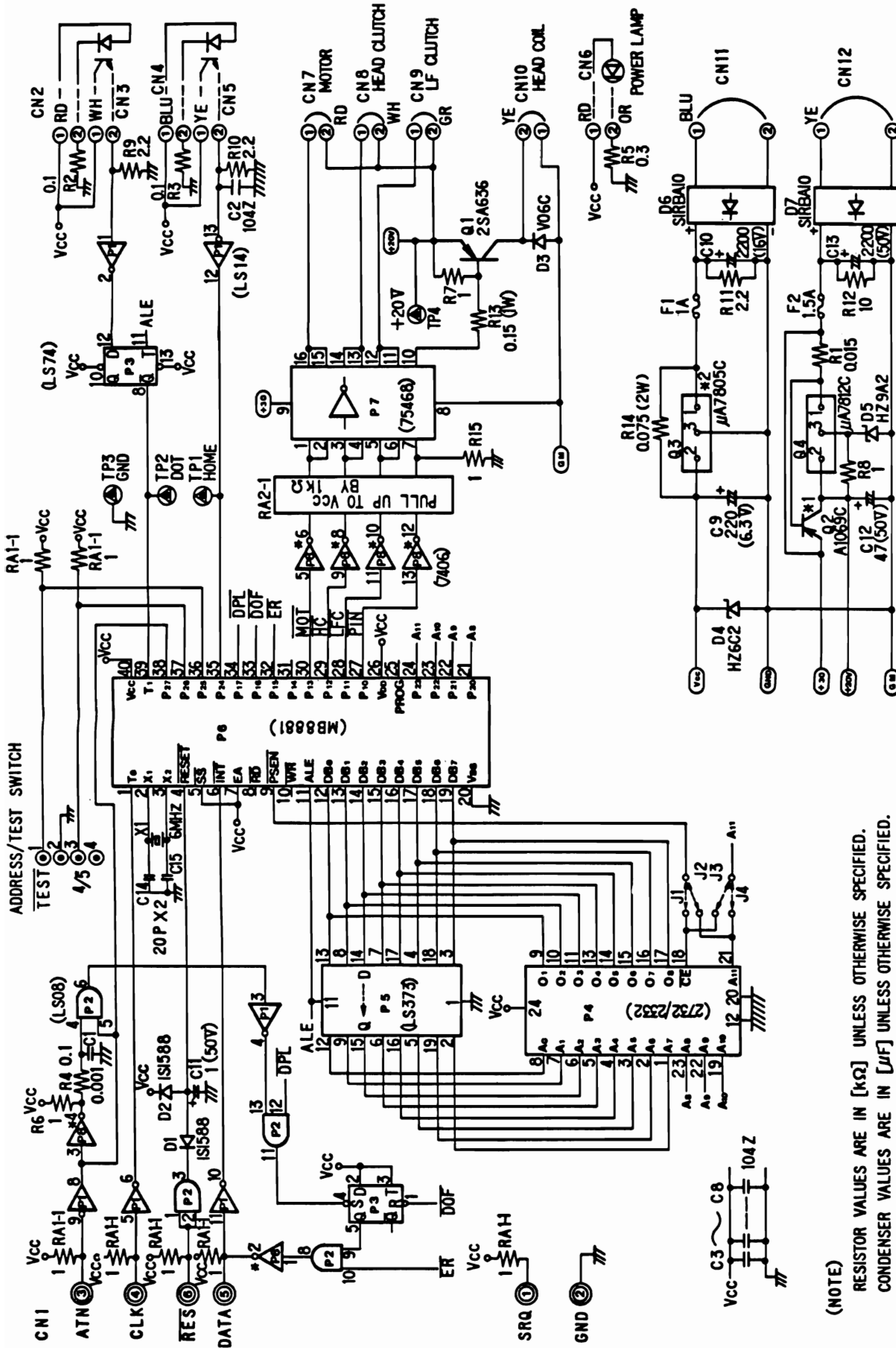

Figure 10

(NOTE)
 RESISTOR VALUES ARE IN [KΩ] UNLESS OTHERWISE SPECIFIED.
 CAPACITOR VALUES ARE IN [μF] UNLESS OTHERWISE SPECIFIED.
 X1, X2 WITH HEAT SINK.
 2732—CONNECT J1, J4 2332—CONNECT J2, J3

(3) Control PCB component view

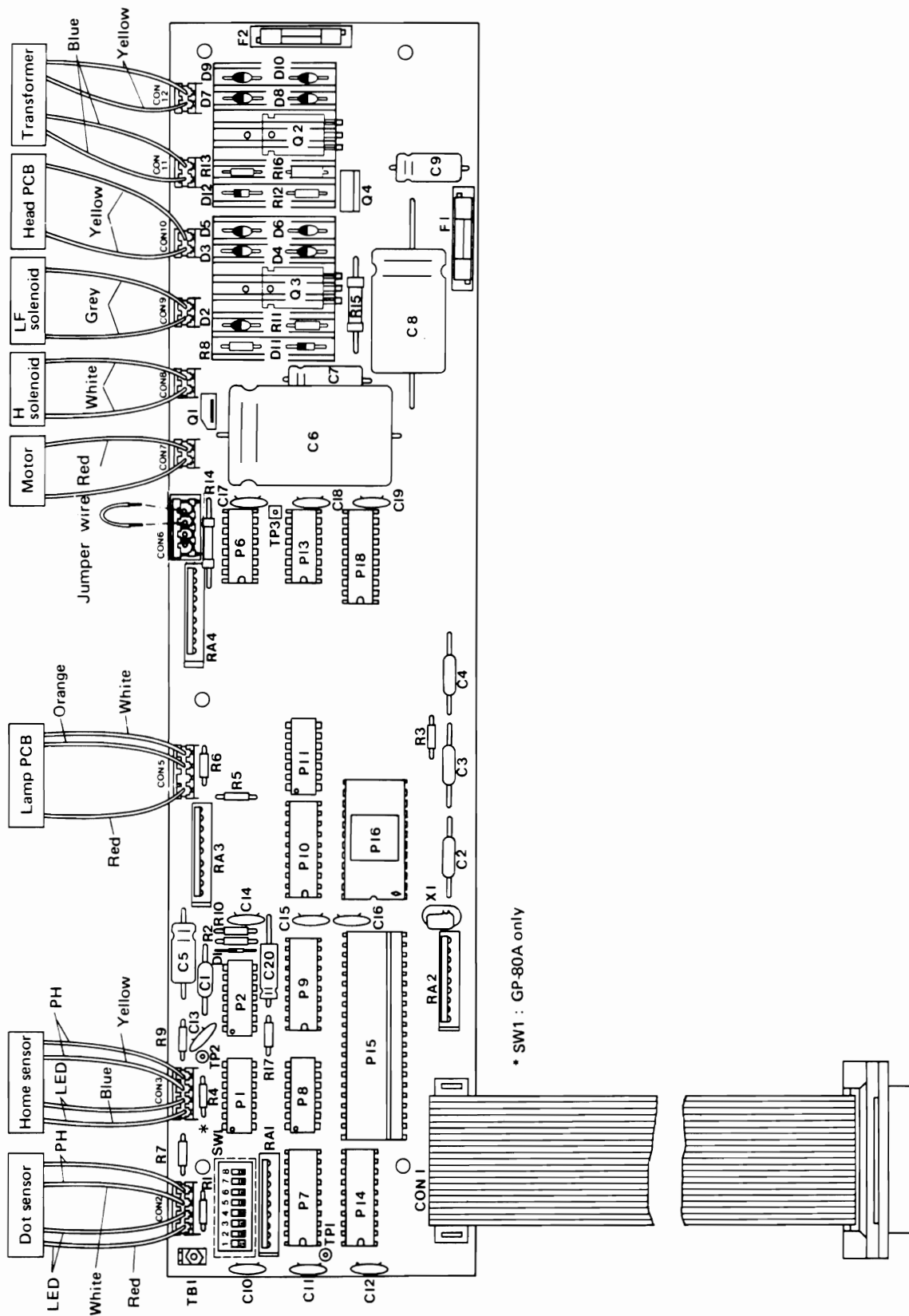

Figure 11

5. TIMING DIAGRAM

(1) Initializing motion

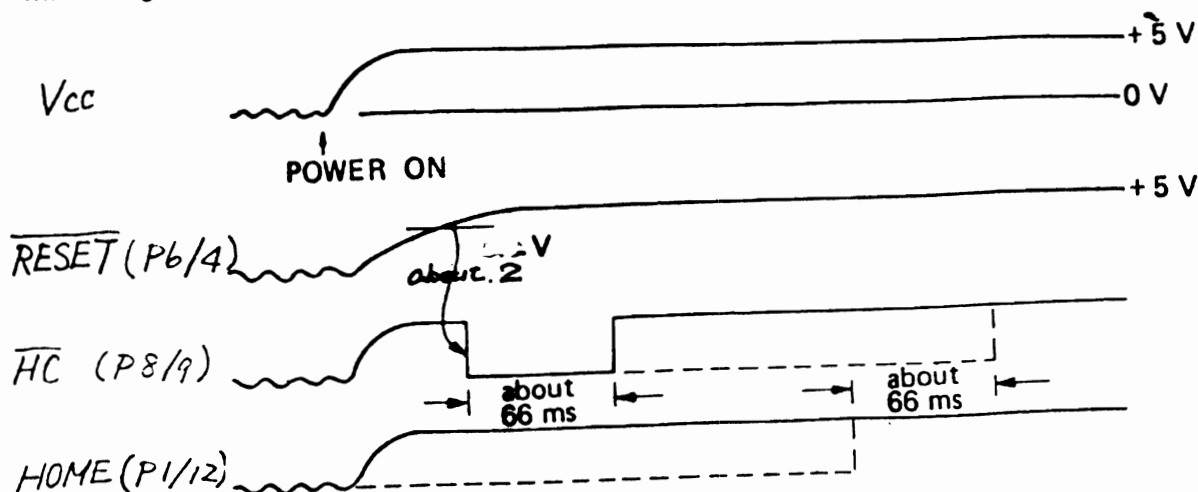
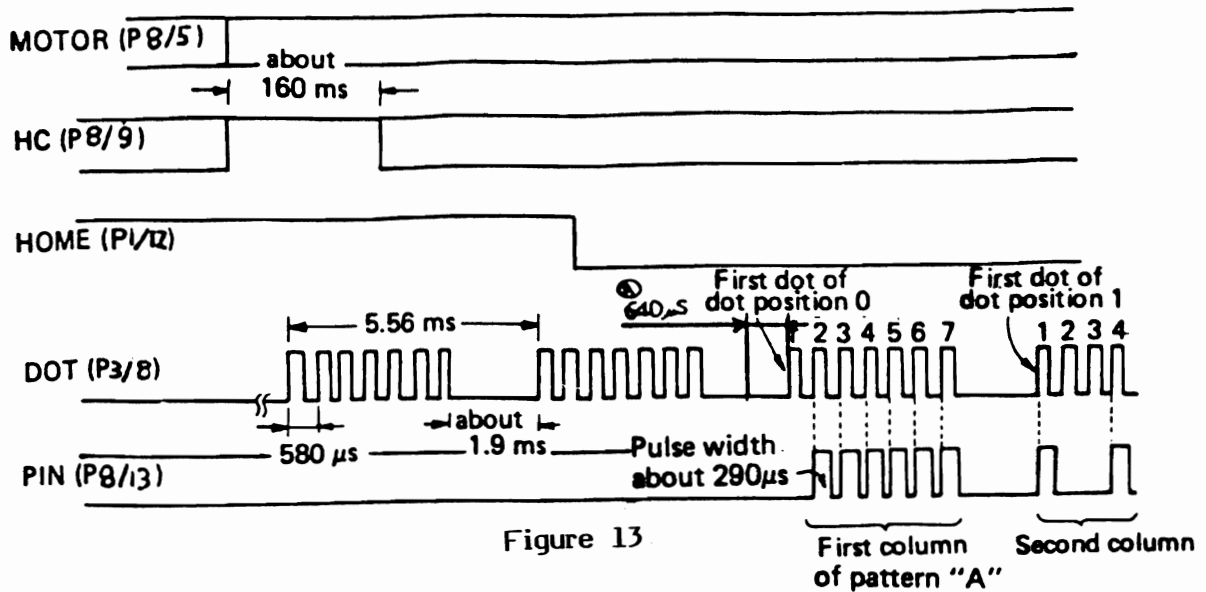

Figure 12

When power is applied, or the \overline{RES} signal is input to P2/1,2 [No.1 and No.2 terminals of IC P2], the CPU (P6/4) accepts the \overline{RESET} signal, the CPU is reset as long as this signal is LOW, or about 2V or less. The CPU activates as soon as it rises from LOW to HIGH. First, the CPU makes the \overline{HC} signal (P8/9) LOW turning on the drivers (P7/13,14). When they are on, the H solenoid is moved to the head carrier return to the home position forced by the recovery spring. The HOME signal (P1/12), which is shaped from the output signal of the home sensor, is HIGH when the head carrier is at the home position and is LOW when out of the home position. The CPU checks the HOME signal to see whether it is HIGH or LOW. If it is HIGH, the CPU will make the \overline{HC} signal HIGH 66 ms later; if it is LOW, the CPU waits until it becomes HIGH and 66 ms later the CPU will make the \overline{HC} signal HIGH. When the \overline{HC} signal becomes HIGH turning the drivers (P7/13,14) OFF (HIGH), the head carrier has returned to the home position with completion of the H solenoid motion. Next is to move the head carrier to the middle of paper and back to the home position in order to check and memorize the timing of rising edge of the HOME signal relatively compared with the DOT signal. This timing will be used as the criterion for the CPU to decide when to start printing. With the above procedure, the printer finishes the initializing motion and can accept input data from this moment. Input and output of the printer are conducted through VIC serial bus.

(2) Start of the printing motions



When printing starts, the CPU makes the \overline{MOT} (P8/5) and \overline{HC} signal LOW. Lowering of the \overline{MOT} signal makes the drivers (P7/15,16) LOW supplying current to the motor to race. Since the \overline{HC} signal is also LOW, the H solenoid is activated to relieve the motor shaft from the head carrier for about 160 ms so that the motor can reach constant speed of revolution. The \overline{HC} signal is raised to HIGH engaging the motor shaft and the head carrier to move it to the rightward direction. In case there is no or abnormal output from the dot sensor, the CPU turns the \overline{HC} and \overline{MOT} signals HIGH and halts to do nothing because mechanical error must have occurred. Next, the CPU waits and sees if the printhead leaves the home position via the HOME signal (P1/12). After confirming that the HOME signal becomes LOW which means the head carrier gets out of the home position, the CPU goes to check the DOT signal (P3/8) in order to decide when to start printing. The DOT signal is a shaped output signal of the dot sensor and a group of 27 sequential pulses repeats at a constant interval. The rising edge of the DOT signal following the comparatively long duration of staying LOW (1.9 ms) is the timing to start printing. When this signal rises from LOW to HIGH after staying LOW for more than 640 μ s, the CPU takes it as a timing to start printing and jumps to the hammer drive routine. In case of printing one dot, the PIN signal (P8/13) of the hammer drive pulse which is synchronized with the DOT signal is made LOW for about 290 μ s. Lowering of the PIN signal makes the driver (P7/I0) LOW, turns the transistor (Q1) ON and drives the hammer. The 27 pulses consist of three 7-dot columns as shown below.

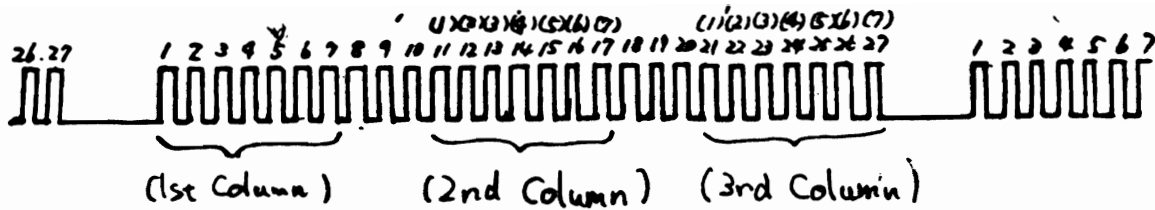

When the HOME signal falls down, the CPU starts counting the number of dot pulses until the DOT signal stays LOW for long (about 1.9 ms). The CPU uses the counted number to compare with the number stored at the initialization in order to decide when to start printing correctly. The HOME and DOT signals can be checked through test pins (TP1, TP2).

(3) Recovery motion

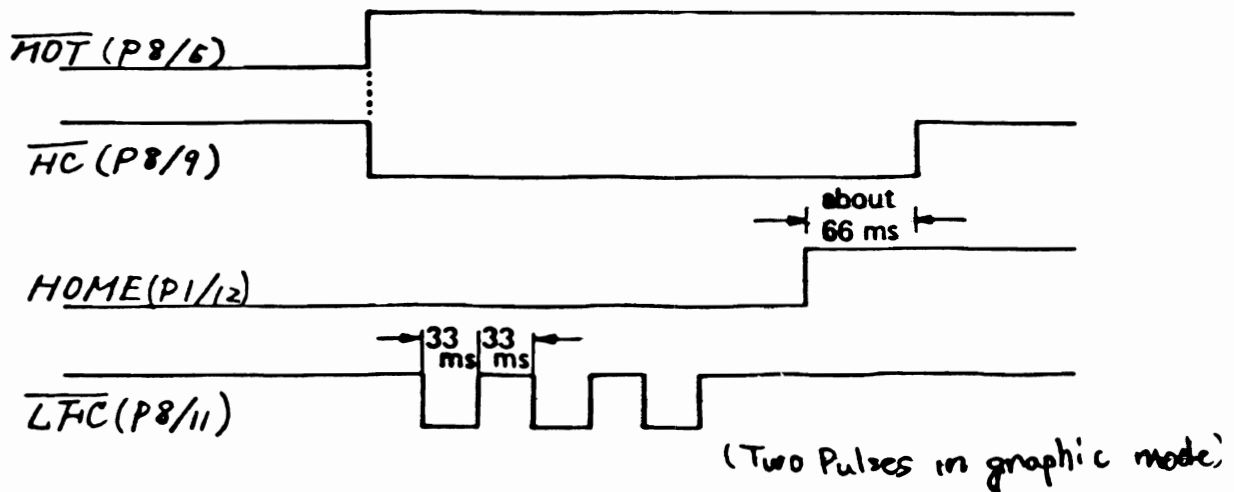

Figure 14

The CPU makes the \overline{MOT} signal HIGH and the \overline{HC} signal LOW after printing a live. With this, the motor stops revolving and the head carrier returns to the home position forced by the recovery spring. If a recovery motion includes a line feed, the output of LFC signal (P8/11) follows. While this signal is LOW, the drivers (P5/11,12) are also LOW activating the LF solenoid for linefeed by 1/18 inch. After linefeed, the CPU waits until the HOME signal returns HIGH. When the head carrier returns to the home position and the HOME signal becomes HIGH, the C signal is raised to HIGH about 66 ms later ending the recovery motion of the head carrier.

III. REPAIRING LEVEL

Follow the sequence below to repair and adjust the Printer.

- ① Remove if an interface is attached.
- ② Proceed the repair according to the repairing levels (A) or (B) described below.
Level (A) : Disassembly, replacing parts, reassembly and adjustment of each mechanism.
Replacing parts of control PCB unit. → (Sophisticated repair)
Level (B) : Replacing blocks including simple parts replacement. Replacing and adjusting the print head. → (Simple repair)
Level (A) and (B) are used in the following chapters to indicate a level of repairing methods.

IV. MEASURING INSTRUMENTS AND TOOLS

The following items are necessary to repair or adjust the Printer.

1. Oscilloscope

This is used to adjust the position of the home sensor unit, or in other words, to adjust the alignment of the printing start position. It is also used to check the control PCB unit.

2. Multimeter (VOM)

3. Print head adjusting tools

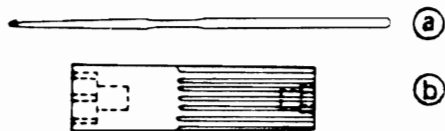

Figure 15

(a) is used to hook a spring to the print head unit and (b) is used to drive the head adjusting nut and the nut. If these tools are not available, use non-magnetic material tools.

4. Tools (screwdriver, tweezers, pliers and nippers)

5. Soldering iron (For electronic parts)

6. Desoldering tool

V. MAINTENANCE

1. CLEANING

Due to its material, each part has its own proper cleaning liquid and method. It should be noted that if an improper cleaning liquid is used or cleaning method is poor, parts may be damaged or may not function properly. Follow the instructions in Table 4 to clean. It is helpful to use a hair drier to dry. But if the cleaning liquid is flammable, take care to keep it away from the hair drier.

Table 4

PARTS	CLEANING METHOD	CLEANING OIL	DRYING METHOD	REMARKS
Metal parts	Brush washing	Benzine or trichloro-ethylene	Warm air	
Plastic parts of the mechanisms	Brush washing	Benzine	Cool air	Do not use any oil other than designated one. Wash quickly, wipe with a cloth and dry rapidly. Use good, clean oil.
Plastic parts of the enclosure	—	—	—	Wipe off dirt.
Rubber parts	—	—	—	Wipe off dirt.
Electric parts <ul style="list-style-type: none"> — PCB u., Motor — H solenoid u., — LF solenoid u., — Dot sensor u., — Home sensor u., etc. — Print head u., — Carrier u. 	Do not wash			Wipe off dirt with a cloth with benzine or alcohol.
Rope parts <ul style="list-style-type: none"> — Feed drum u. — Head rope (L) u. — Claw wheel u. 	Do not wash			Do not wipe or touch the rope. Lubricate with oil only.

2. LUBRICATING

Use the following lubricants in repairing and adjusting the Printer. Portions needed to lubricate are described in the next chapter, VI DISASSEMBLY AND REASSEMBLY.

SF-100
 J-5
 Screwlock

VI. DISASSEMBLY AND REASSEMBLY

If there are two levels to repair, Ⓐ and Ⓑ are used to describe the difficulties of repairing methods. To disassemble, follow the sequences written in each figure and follow the sequences in the reverse order to reassemble.

1. UPPER CASE

1-1	Soundproof cover
S-36	Tapping screw M3 x 16
1-2	Cover unit
1-3	Upper case unit

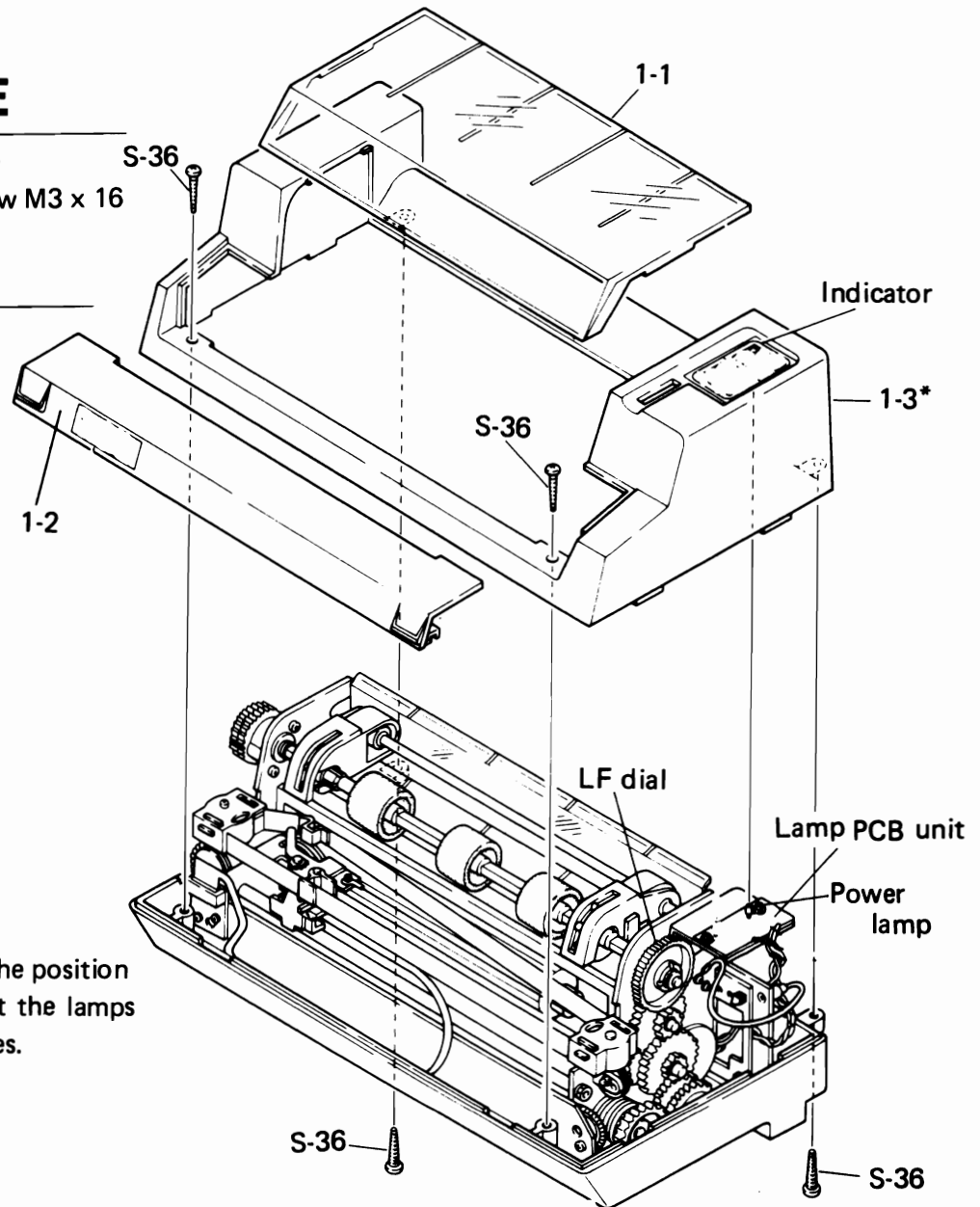

* When attaching 1-3, adjust the position of the lamp PCB unit so that the lamps are at the centers of the holes.

● Confirming the function

Follow the procedures below to confirm the functions.

- (1) After applying power, check whether the power lamp being lit and the printer initialized.
- (2) Check whether paper advances properly with LF dial.
- (3) Is ribbon advancing?
- (4) Is it possible to set paper properly?
- (5) Check printed characters (wrong printing, character missing or smudging).
- (6) Is the aligning of the start position of printing properly achieved?
- (7) Is the last column printing possible?
- (8) Is there any abnormality in character width, height or space between characters?
- (9) Is there any dot missing at upper or lower part of characters?
- (10) Are printed characters vivid? Is there any dirt caused by ribbon?
- (11) Is the spacing of linefeed proper?

Figure 16

2. LOWER CASE BLOCK AND MACHINE ASSEMBLY

2-1	Ribbon cassette	
S-45	Screw	M4 x 0.7 x 5
W-42	Spring washer	M4
W-43	Toothed lock washer	M4
2-2	M. stop screw	
2-3	Lower case block	
2-4	Machine assembly	

Part (K) setting note

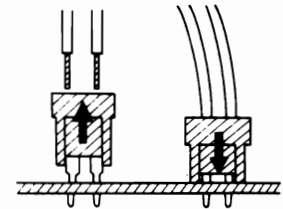

Insert twisted ends of lead wire and make sure they are not shorted.

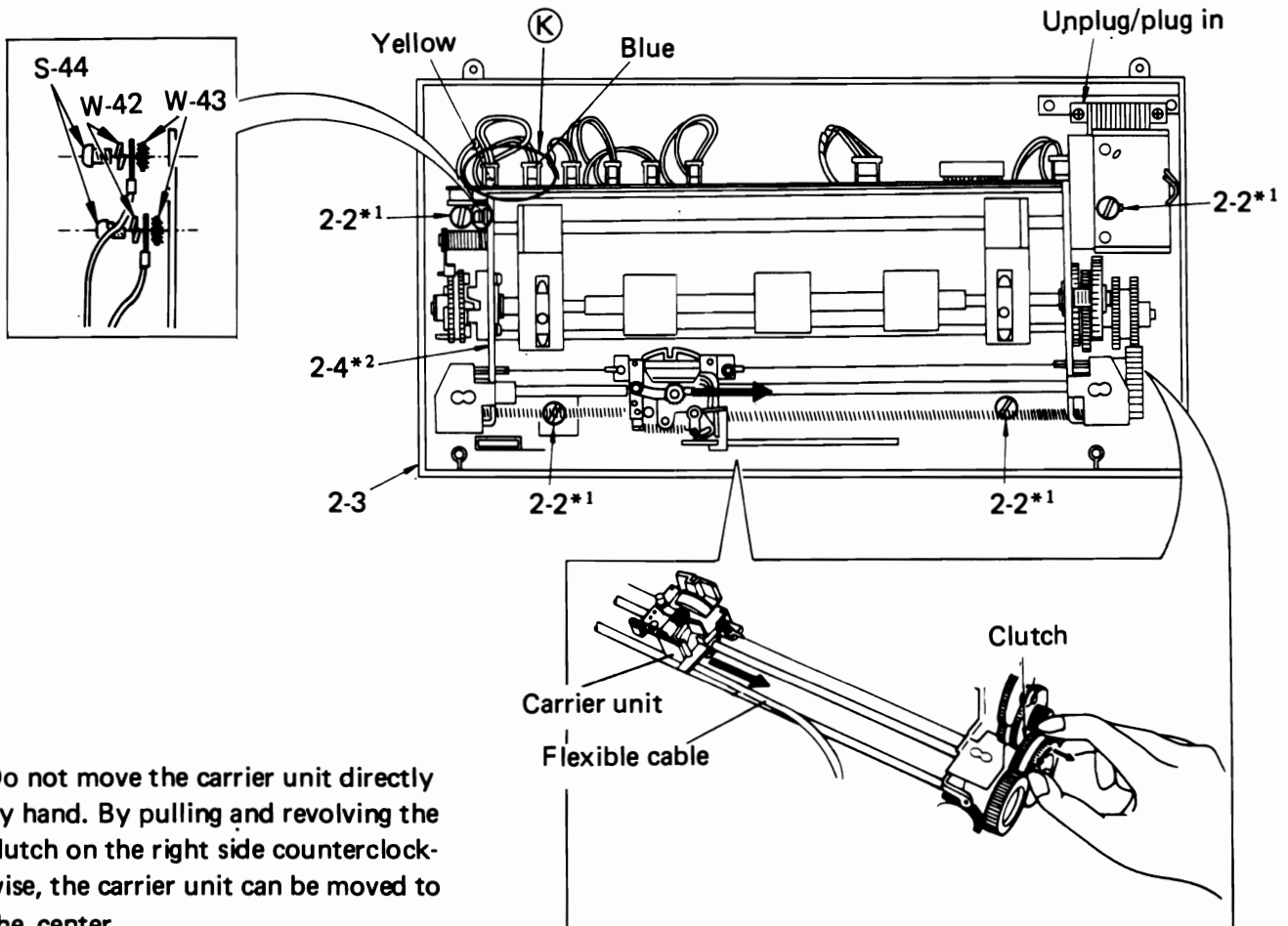

Do not move the carrier unit directly by hand. By pulling and revolving the clutch on the right side counterclockwise, the carrier unit can be moved to the center.

Figure 17

*1 Before replacing 2-3 and 2-4 with 2-2, the carrier unit must be moved to the center. When setting 2-3 and 2-4, be careful not to catch the lead wires or the recovery spring between 2-3 and 2-4, and to damage or to injure them.

*2 Pay attention not to damage the flexible cable.

Note: The repair procedures for 2-3 and 2-4 are described on page 23 and on.

● Adjustments for printing

Make the following adjustments after setting the ribbon cassettes and paper.

(1) Adjusting the position of the dot sensor

Print characters and check the darkness of the upper and the lower part of characters. If the darkness is not equal, adjust the position of the dot sensor.

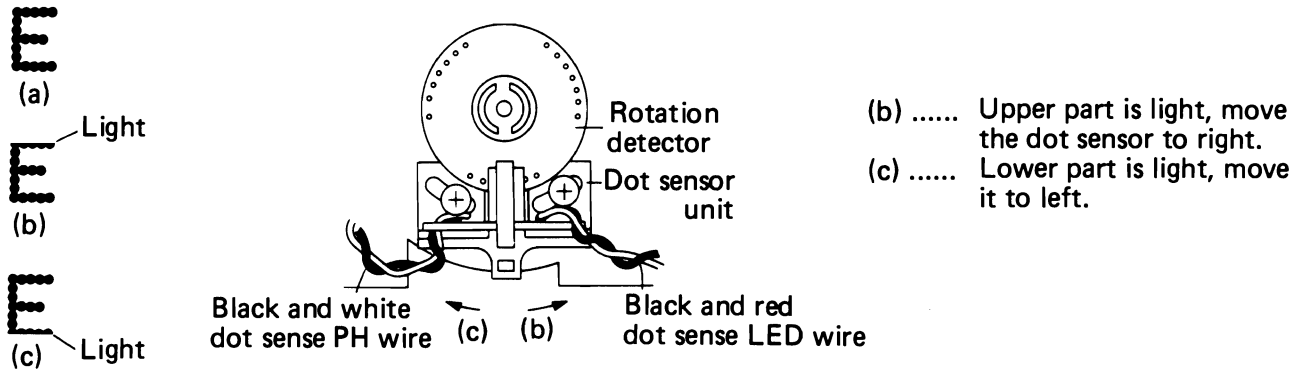

Figure 18

(2) Adjusting the printing start position with the carrier unit and the home sensor

i) The gaps between the carrier unit and the home sensor

Gaps A and B should be about 0.5 mm, with B smaller than C. The gaps can be adjusted by twisting oblique line part of the earth plate (L).

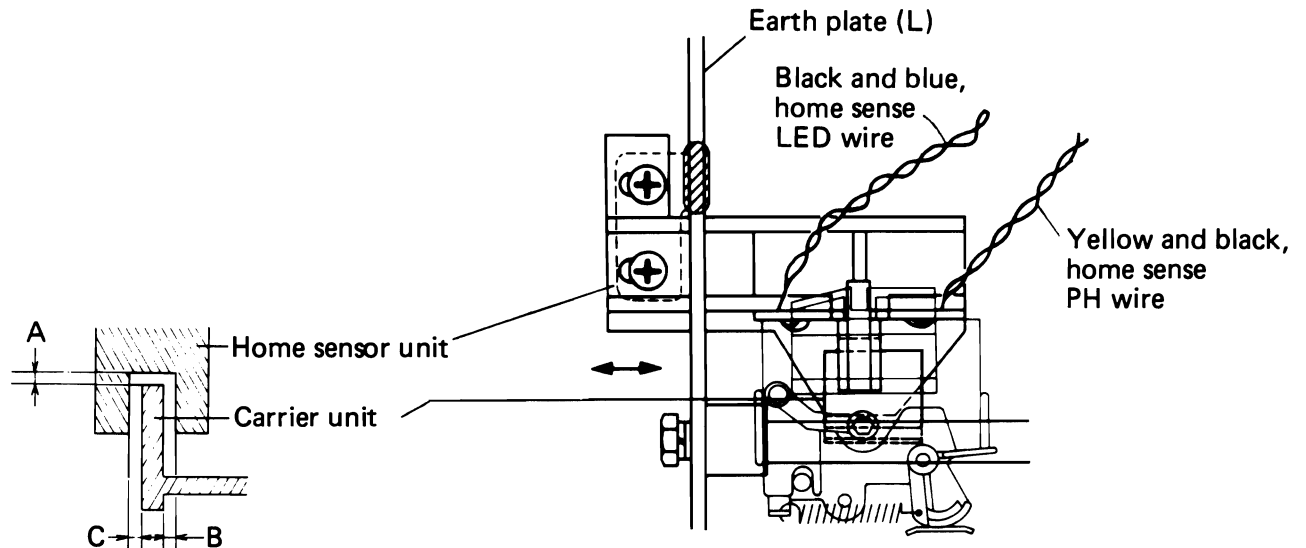

Figure 19

ii) Adjustment for aligning the start position of printing

(Connect TP1 and TP2 of PCB unit to oscilloscope)

Adjust the position of the home sensor unit so that the falling-edge of the home sensor pulse can be within the permissible range of the dot sensor pulses.

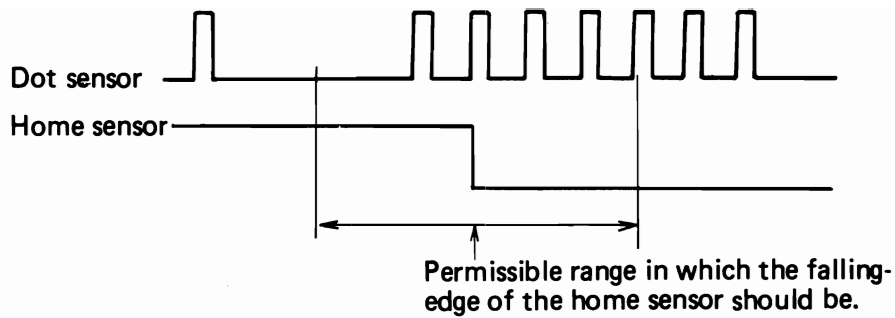

Figure 20

If the falling-edge of the home sensor pulse shifts to right Shift the home sensor unit to right.

If the falling-edge of the home sensor pulse shifts to left Shift the home sensor unit to left.

(3) Adjusting the print head unit

- i) By using a print head adjusting tool to tighten the head adjust nut, proper darkness of the printed character can be obtained. If there appears to be smudging, loosen it until smudging disappears.
- ii) Set the head adjust lever at the hole ①.
- iii) With a print head adjusting tool, tighten the nut so that the head adjust lever could be moved without too much force. Then lubricate screwlock on the hexagon nut.

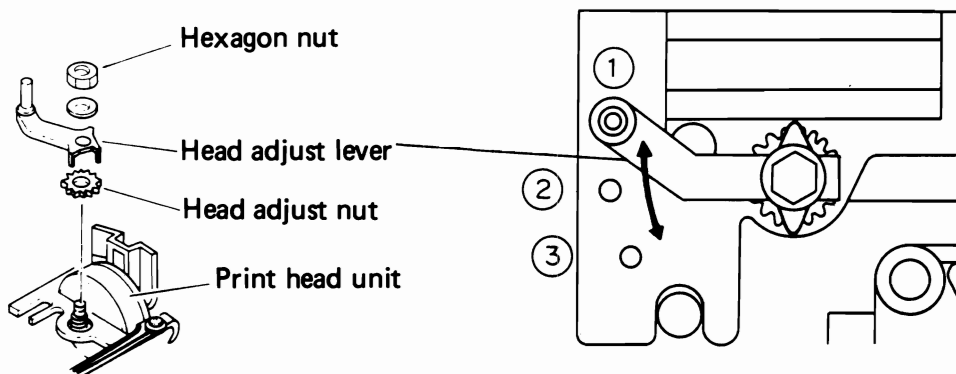

Figure 21

Note: As the print head unit is made of magnetic metal, do not use magnetized tools to adjust.

● **Confirming the function**

Confirm all the items described on page 19

3. LOWER CASE BLOCK

Repairing methods

Level (A) : Replace a defective part

Level (B) : Replace a part if 3-6 to 3-8 are defective. Replace the lower case block if 3-1 to 3-5 or 3-9 are defective.

M-01	Extruded tubing	$\phi 5 \times 0.25 \times 12$ mm
M-20	Splice	35115
S-02	Tapping screw	M3 x 12
S-43	Tapping screw	M4 x 8
N-02	Wire band B	
S-28	Tapping screw	M2.6x6
N-02	Hexagon nut	M2.6x0.45
3-1	Harness (Transformer GND harness)	
3-2	Transformer	
*S-37	Screw with spring washer M3 x 0.5 x 4. For M ₀₂ only.	
3-3	Sw. stopper	
3-4	Power switch	
3-5	Cord bush	
3-6	Power cord	
3-7	Fuse holder	
*3-8	Fuse holder washer.	
3-9	Connector cover plate unit	
3-10	Lower case unit	

Note: * indicates there is a model which does not use this part.

● **Harness diagram**

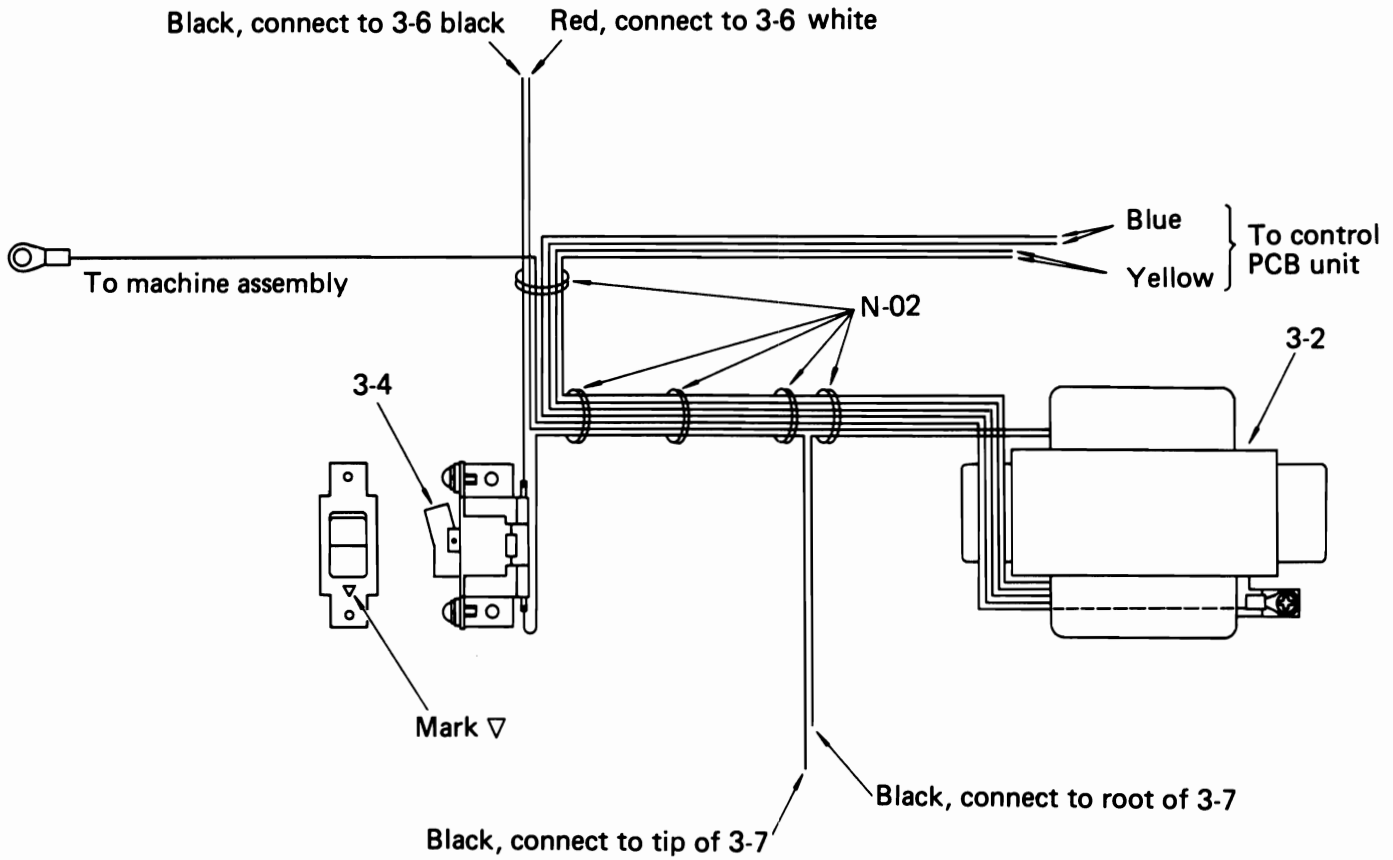

Figure 21

● **Harness diagram**

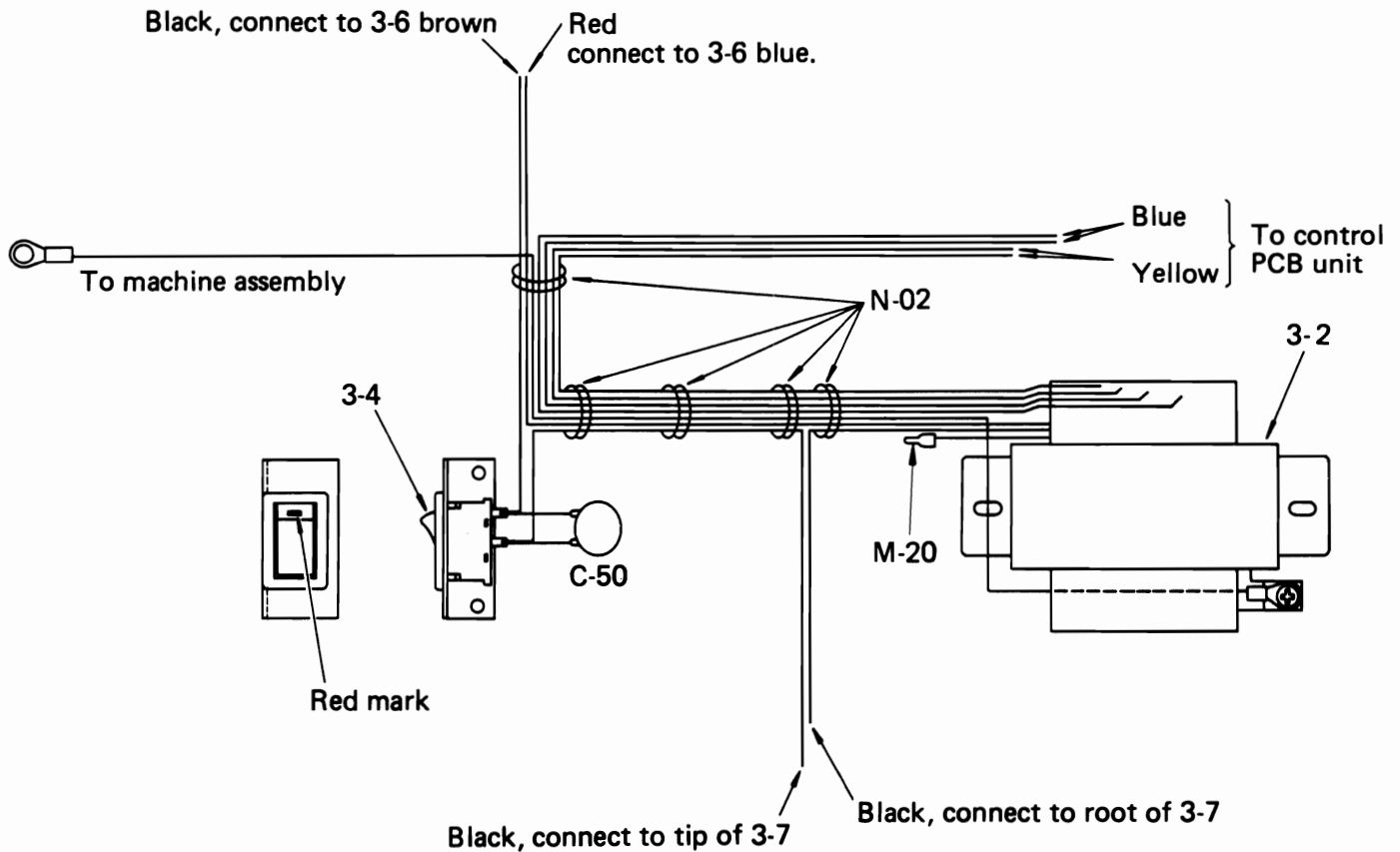
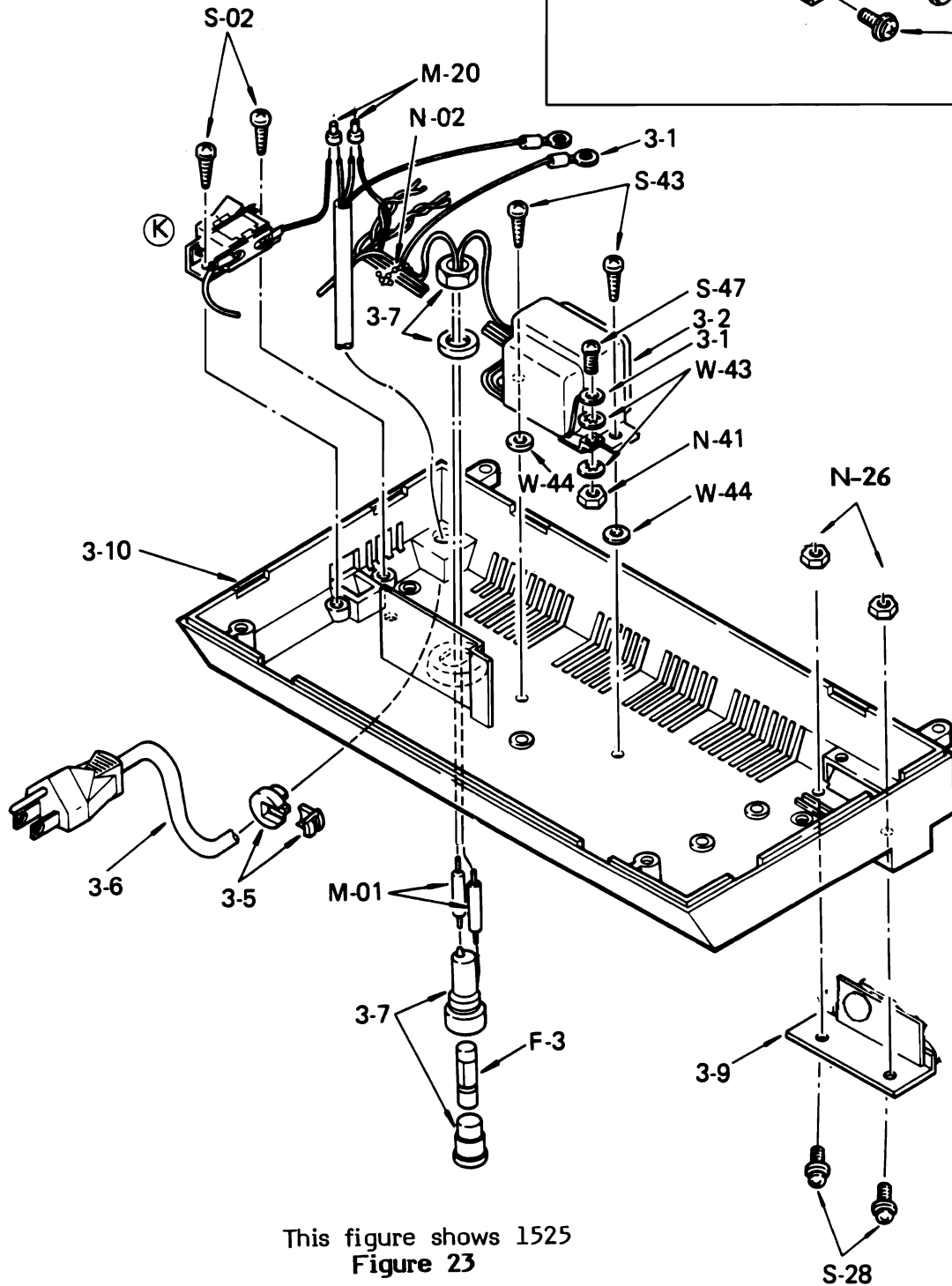
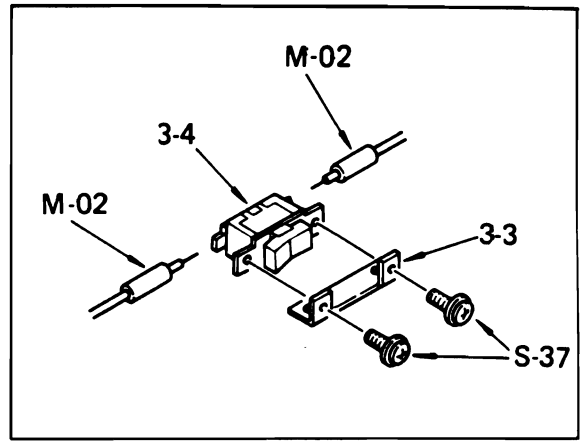

Figure 22

Details of part (K)



This figure shows 1525
Figure 23

4. CONTROL PCB UNIT AND LAMP PCB UNIT

Repairing methods

Level (A) : Repairing PCB unit or replacing defective parts. When fixing PCB unit, refer to the circuit diagram (Figure 10), the PCB view (Figure 11) and the timing diagrams (Figure 12 ~ 14).

Level (B) : Replacing defective parts

S-42	Tapping screw M4 x 12
4-1	Control PCB unit
F-2	Fuse (1.5A)
F-1	Fuse (1A)
4-3	PCB receptacle
S-21	Screw M2 x 0.4 x 6
W-21	Spring washer M2
W-24	Plain washer M2
4-4	Lamp PCB unit
4-5	Lamp
N-01	Wire band A
N-02	Wire band B

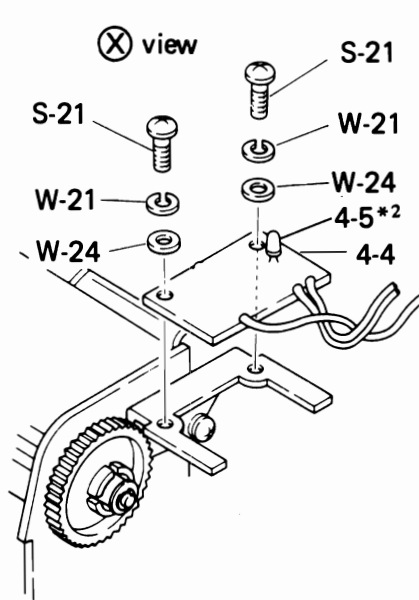

*1 Lead wire setting note

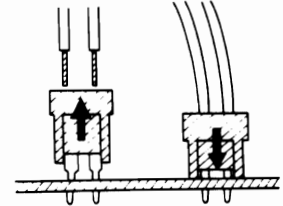

Insert twisted ends of lead wire and make sure they are not shorted.

*2 4-5 attachment

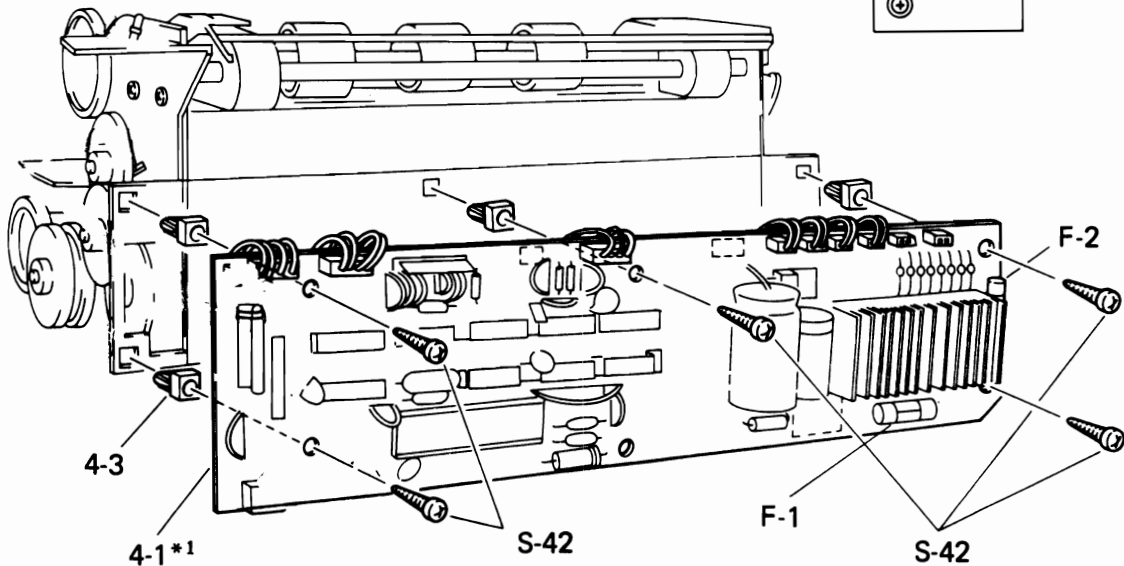
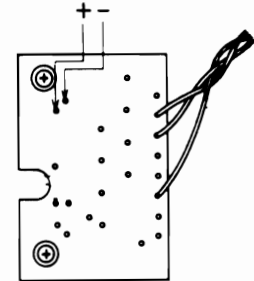
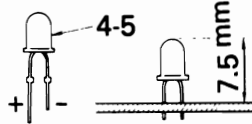
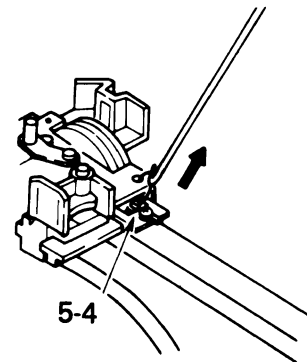

Figure 23

5. PRINT HEAD UNIT

N-21	Hexagon nut (brass) M2 x 0.4
W-23	Plain washer M2 (brass)
5-1	Head adjust lever
5-2	Head adjust nut
S-22	Screw (brass) M2 x 0.4 x 3
W-23	Plain washer M2 (brass)
5-3	Cable guide
5-4	Head adjust spring
5-5	Print head unit
5-6	Head spacer
S-31	Screw M3 x 0.5 x 6
5-7	Head board unit
5-8	Head connector

*1 Removing the hook of 5-4 using a print head adjusting tool.



*2 Be sure to get rid of dust, especially iron dust, from 5-5. Be careful not to hurt the flexible cable. When reassembling, keep pulling the clutch and revolve it counterclockwise to move the carrier unit to the center (Refer to Figure 17)

*3 Barely tighten 5-2 with the print head adjusting tool (tacking). N-21, W-23 and 5-1 should be set after adjusting the print head.

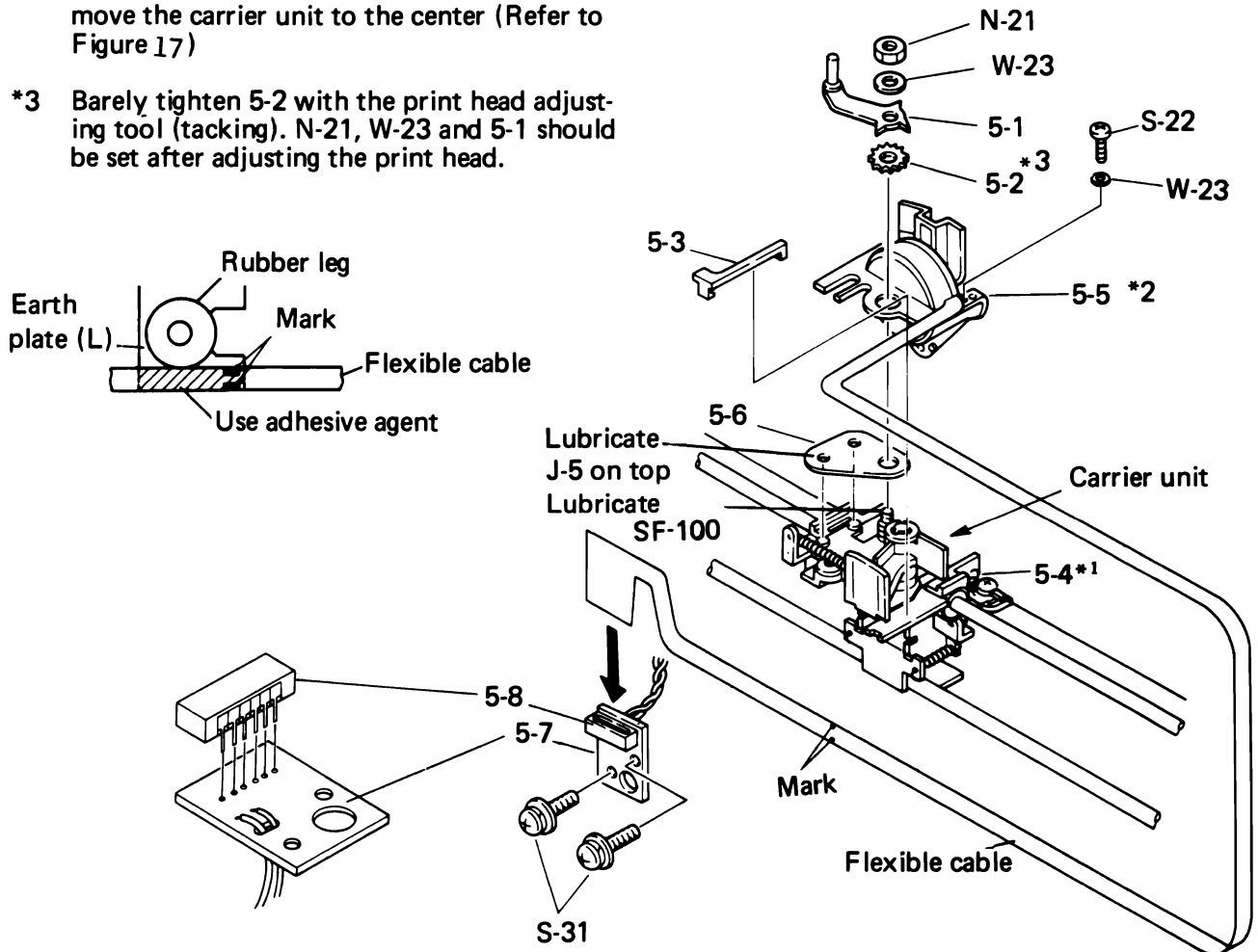

Figure 24

6. LINEFEED MECHANISM

Repairing methods

Level (A) : Checking, adjusting or replacing parts

Level (B) : Replacing machine assembly except checking, cleaning, lubricating or adjusting / replacing 6-1 to 6-3.

6-1	LF rope spring
E-40	E-40 ring
W-51	Plain washer small M5
6-2	Reverse stop claw
6-3	Reverse stop spring
S-28	Screw M2.6 x 0.45 x 6
S-31	Screw M3 x 0.5 x 6
6-4	LF solenoid unit
E-38	BE-37 ring
6-5	LF claw wheel
6-6	Gear pin
6-7	Claw wheel unit
6-8	Claw wheel spring
S-32	Screw M3 x 0.5 x 8
6-9	LF claw stopper
E-37	E-37 ring
6-10	LF dial
6-11	Dial clutch spring
W-61	Plain washer small M6

*1 6-6 should be in the groove of 6-5, but not in that of 6-7.

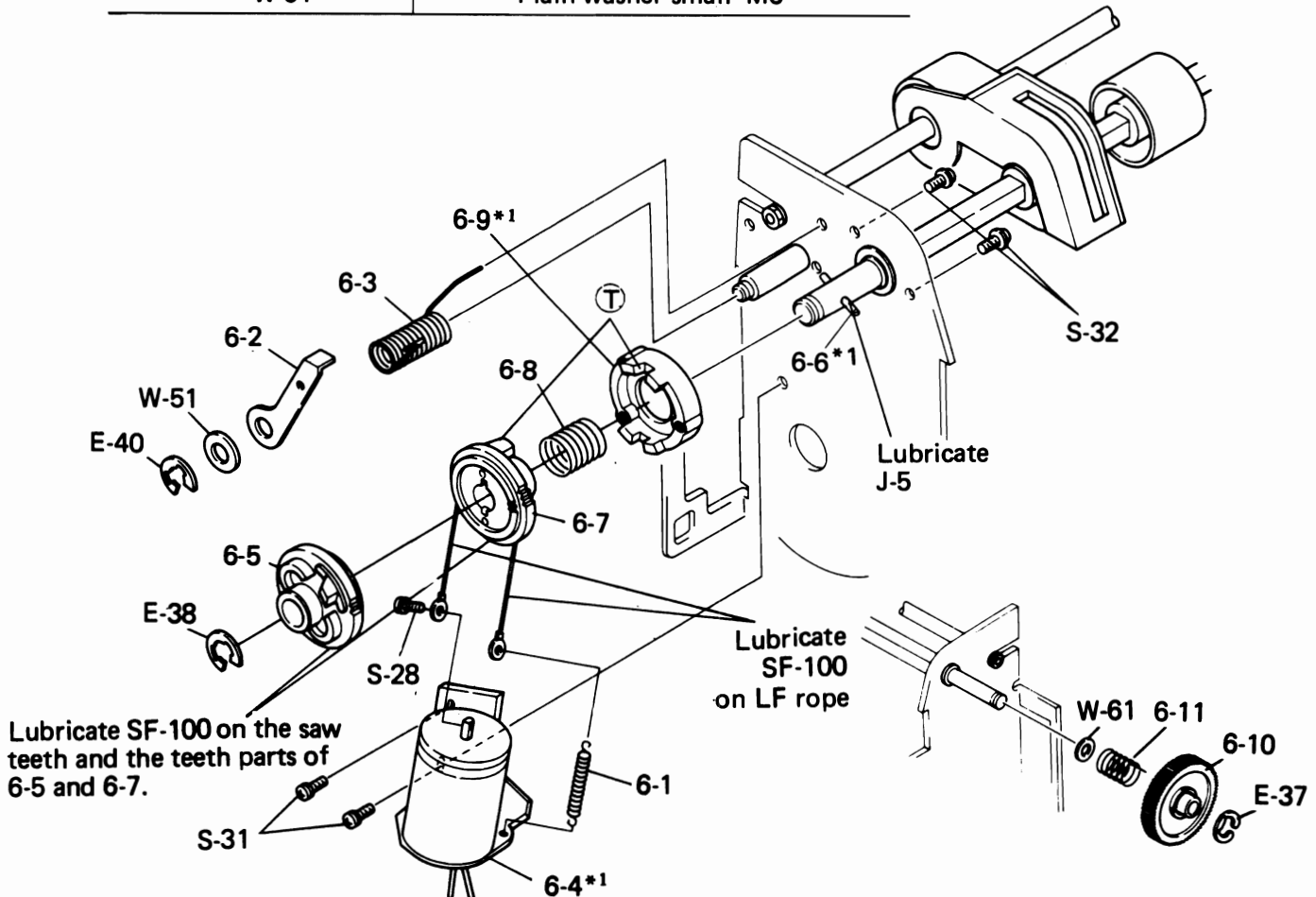
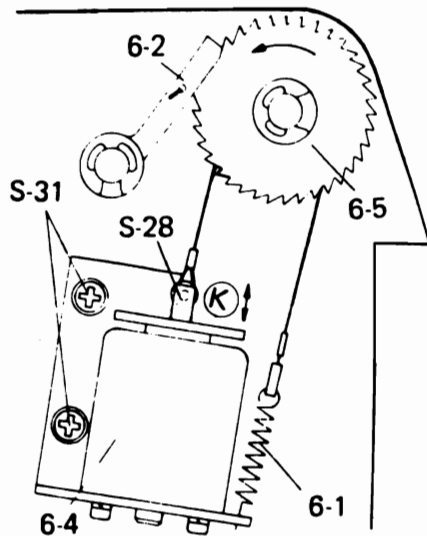

Figure 25

*1 6-4 and 6-9 adjusting method



- i) While pushing down part (K) of 6-4, fix 6-4 with S-31 at the position where 6-2 falls from a tooth top of 6-5. The screw S-28 should be set to the direction as shown in the left figure.
- ii) While pressing part (K) of 6-4, fix 6-9 with S-32 at the position where (T) part of 6-9 and (T) part of 6-7 are coupled to stop the revolution of 6-7.
- iii) Confirm linefeed functions by pressing part (K).

7. FEED DRUM AND CARRIER UNIT

Repairing methods

Level (A) : Checking, adjusting or replacing parts

Level (B) : Replacing machine assembly except checking, cleaning, lubricating, adjusting / replacing 7-2, 7-10, 7-15 and 7-16, or adjusting the ribbon feed board.

S-30	Screw M3 x 0.5 x 4
W-32	Plain washer small M3
7-1	FPC guide
7-2	Recovery spring
S-29	Screw M2.6 x 0.45 x 8
7-3	Rope spring
7-4	Rope stopper (1 set)
7-5	Head rope (L) unit
7-6	Feed drum unit
7-7	Drum spring step
7-8	Drum spring
E-25	BE-24 ring
7-9	Pulley pin
7-10	Spring pulley
7-11	Rope pulley
N-31	Hexagon nut M3 x 0.5
W-31	Spring washer M3
W-32	Plain washer small M3
7-12	Guide pillar
7-13	Damper
7-14	Carrier unit
7-15	Ribbon cam spring
E-24	E-24 ring
7-16	Ribbon cam

Lubrication on 7-10, 7-11
and the shaft of 7-6

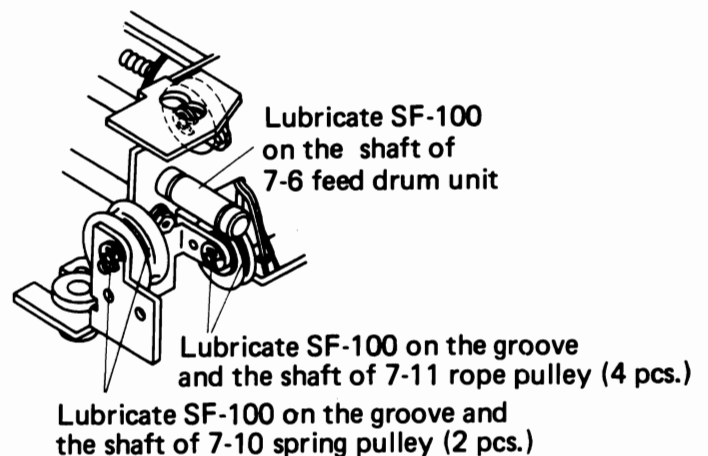

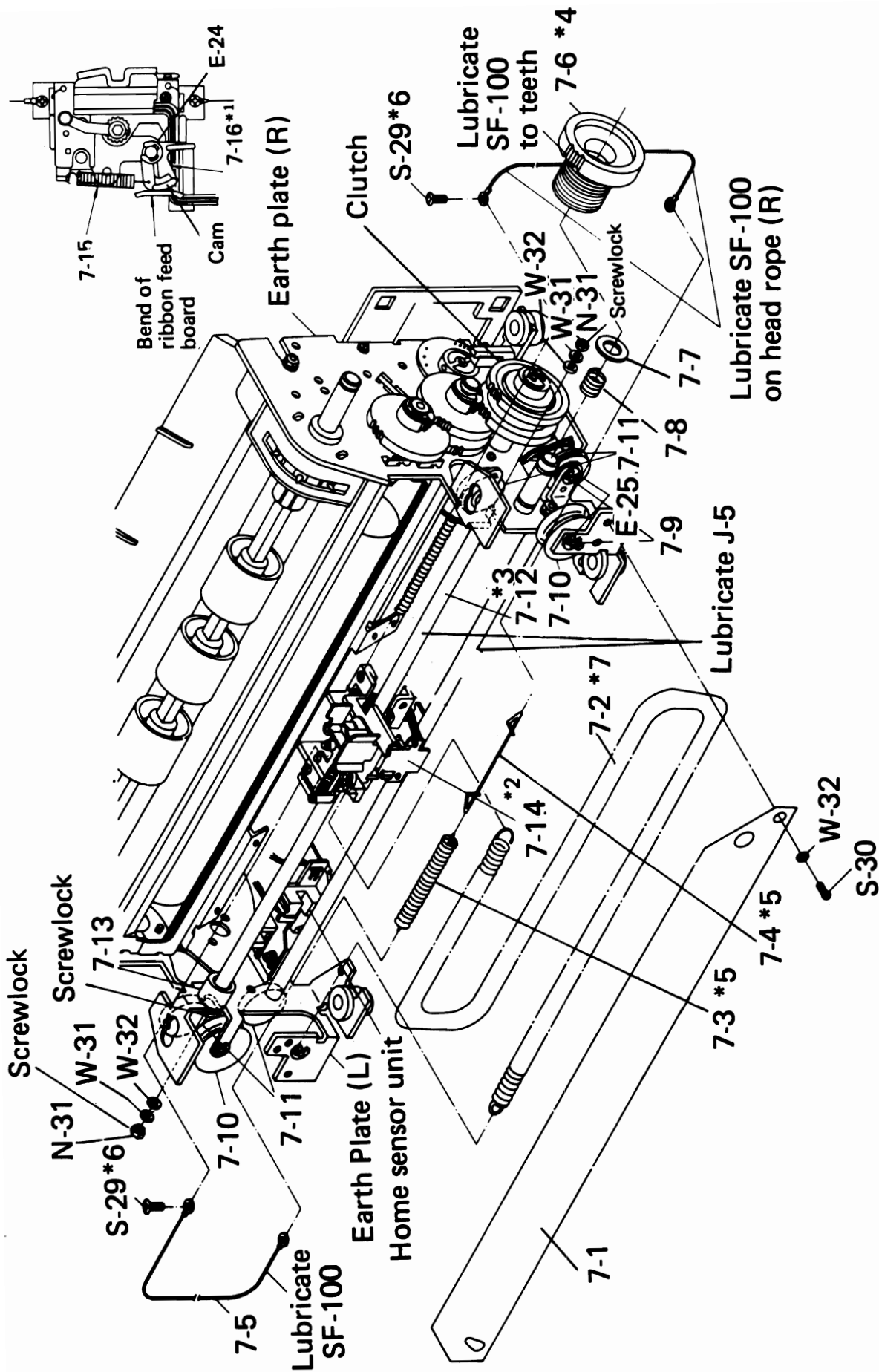
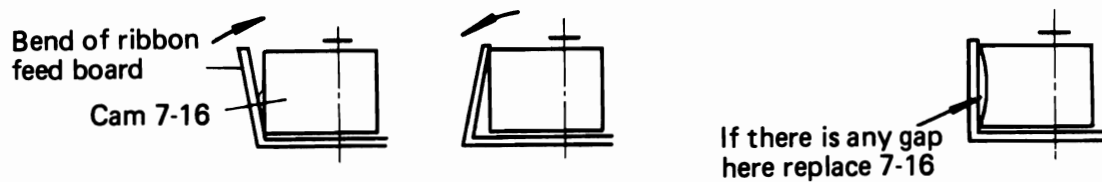

Figure 26

- *1 The cam 7-16 and the bend of the ribbon feed board must be parallel. If not parallel, ribbon feeding may function abnormally. In this case, you can either change 7-16 or adjust the bend of the ribbon feed board by using pliers to fit the cam 7-16.



- *2 When 7-14 is at the home position, there should be gaps between the home sensor (Refer to Figure 19.).
- *3 Firmly insert 7-12 into the earth plate (R) and (L), and tighten with N-31.
- *4 Once you have removed the feed drum unit 7-6, you must install a new one. A new one, which has six winds of the head rope (R), is fixed by a fixing tool. the fixing tool should be taken off after you have finished assembling with S-29 screws.

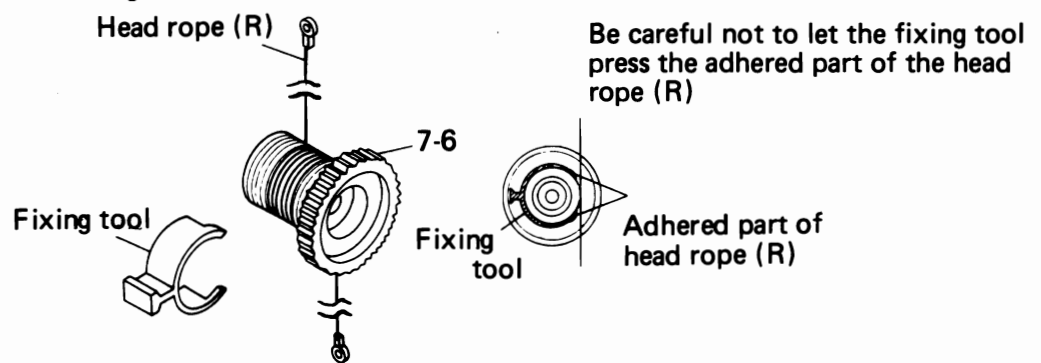

Figure 27

- *5 Insert the rope stopper 7-4 into the rope spring 7-3.
- *6 To fix the head rope (L) and (R) using screw S-29:
 - Inject screwlock into the screw hole of the carrier unit.
 - Tighten the screw S-29 to the extent that the rings of the head rope (R) and (L) can be revolved.

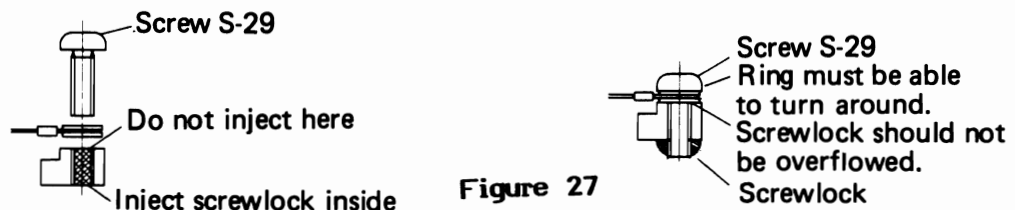

Figure 27

- *7 Check the following after attaching the recovery spring 7-2. After manually pulling and revolving the clutch counterclockwise to move the carrier unit to the right end, check the gaps of the rope stopper 7-4 and the adhered position and status of the feed drum unit 7-6.

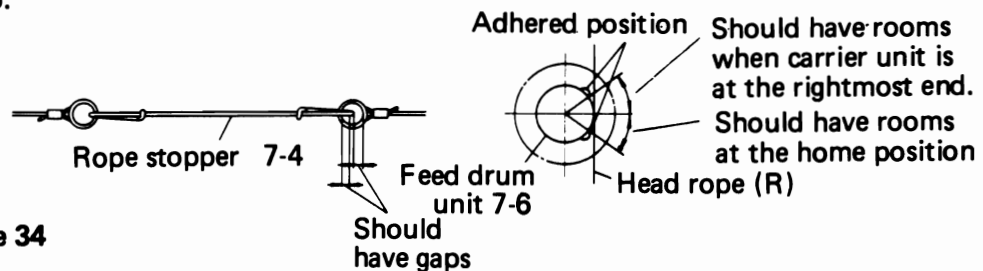

Figure 34

After pressing the H solenoid to release the clutch (Figure 6), check the smooth motion of the carrier unit, its return to the home position, and also the adhered position and its status of the feed drum unit 7-6 at the home position.

8. GEAR TRAIN

Repairing method.

Level (A) : Checking, adjusting or replacing parts

Level (B) : Replacing machine assembly except checking, lubricating or replacing / adjusting 8-1 and 8-2.

8-1	Clutch moving spring
S-31	Screw M3 x 0.5 x 6
8-2	Dot sensor unit
E-28	E-28 ring
8-3	Clutch step
8-4	Clutch
8-5	Spring pan
8-6	Clutch spring
8-7	Clutch
E-37	E-37 ring
8-8	Reduction gear
8-9	Gear pin
8-10	Rotation detector
E-38	BE-37 ring
8-11	Reduction gear
8-12	Gear pin
8-13	Reduction gear
S-26	Screw M2.6 x 0.45 x 4
8-14	H solenoid
S-33	Screw M3 x 0.5 x 5
8-15	Motor

*1 The way to set 8-10 and 8-9.

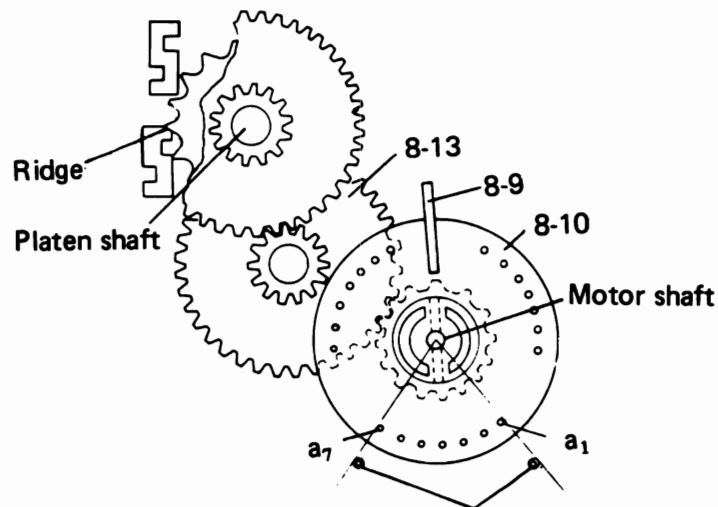

Figure 28

Screw-holes for fixing the dot sensor of the earth plate (R)

- Attaching method of 8-10
When a platen ridge is at the horizontal position, couple 8-10 and 8-13 in the status of a_1 and a_7 of 8-10 facing the two screw holes of the earth plate (R) respectively.
- Attaching method of 8-9
Fit the holes of 8-10 and the motor shaft, and then insert 8-9 using pliers.

*2 First, insert the M. stop screw into the rubber leg (Figure 17), and then fix 8-2 by S-31. Make sure there are gaps between the grooves of 8-2 and 8-10.

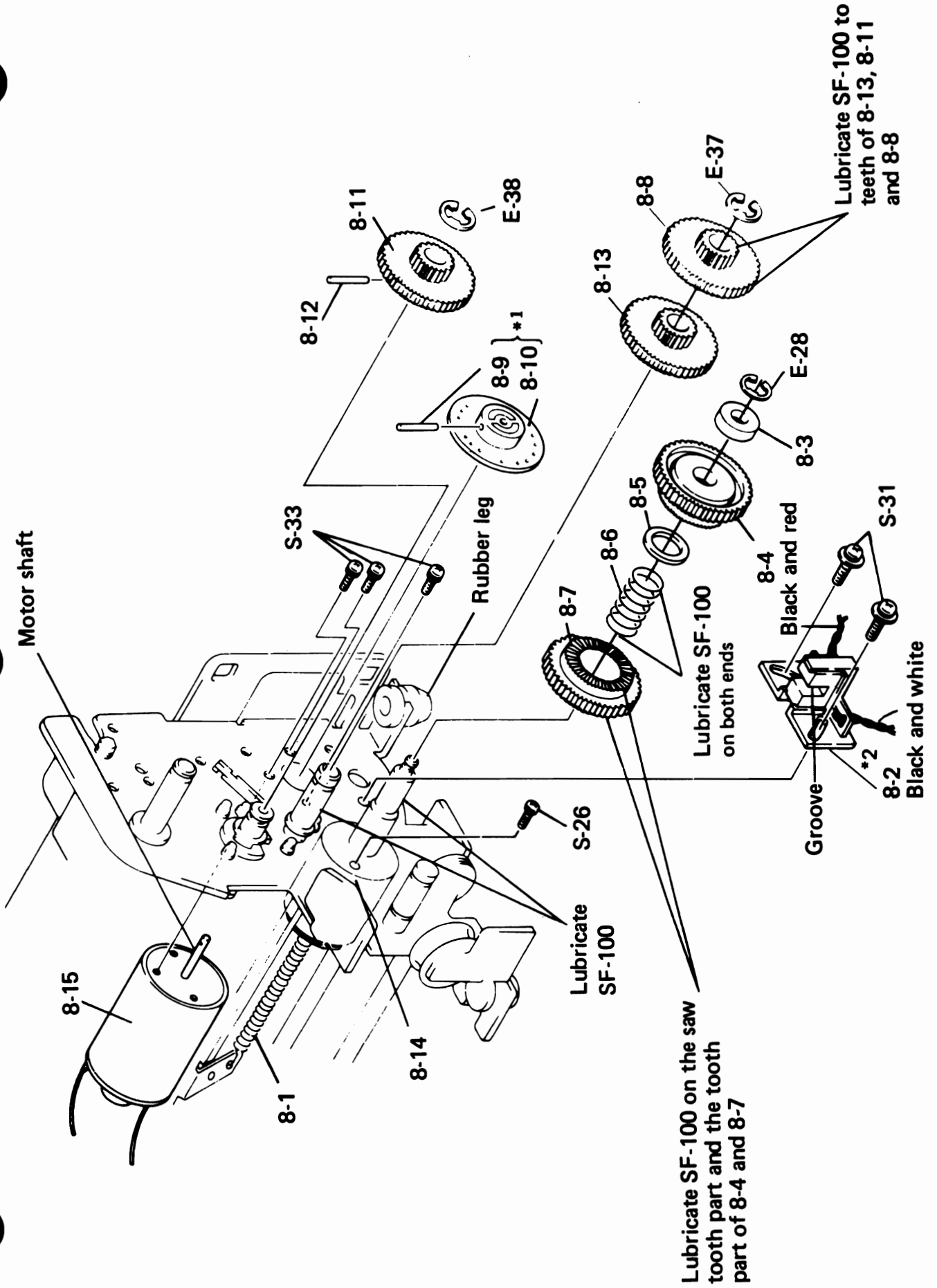

Figure 29

9. TRACTOR

Repairing methods

- Level (A) : Checking, adjusting or replacing parts. Replacing machine assembly if earth plate block is defective.
- Level (B) : Replacing machine assembly except checking, lubricating or checking/adjusting/replacing parts of 9-1 to 9-4, 9-9 and 9-10.

S-32	Screw M3 x 0.5 x 8
9-1	Soundproof
N-31	Hexagon nut M3 x 0.5
W-31	Spring washer M3
W-32	Plain washer small M3
9-2	Guide pillar
9-3	Paper holder (L) unit
9-4	Paper holder (R) unit
E-75	BE-74 ring
9-5	Platen bearing (Bearing for tractor)
9-6	Tractor shaft
9-7	Pin feed roller
9-8	Tractor rubber ring
E-60	CE-6 ring
S-32	Screw M3 x 0.5 x 8
9-9	Home sensor unit
9-10	Rubber leg

- *1 Push 9-9 outside as far as it will go and fix with S-32.
- *2 Assemble the two 9-7 so that the pins of them are facing each other.
- *3 Check that the surface of 9-6 (L) part is smooth and has no scar.

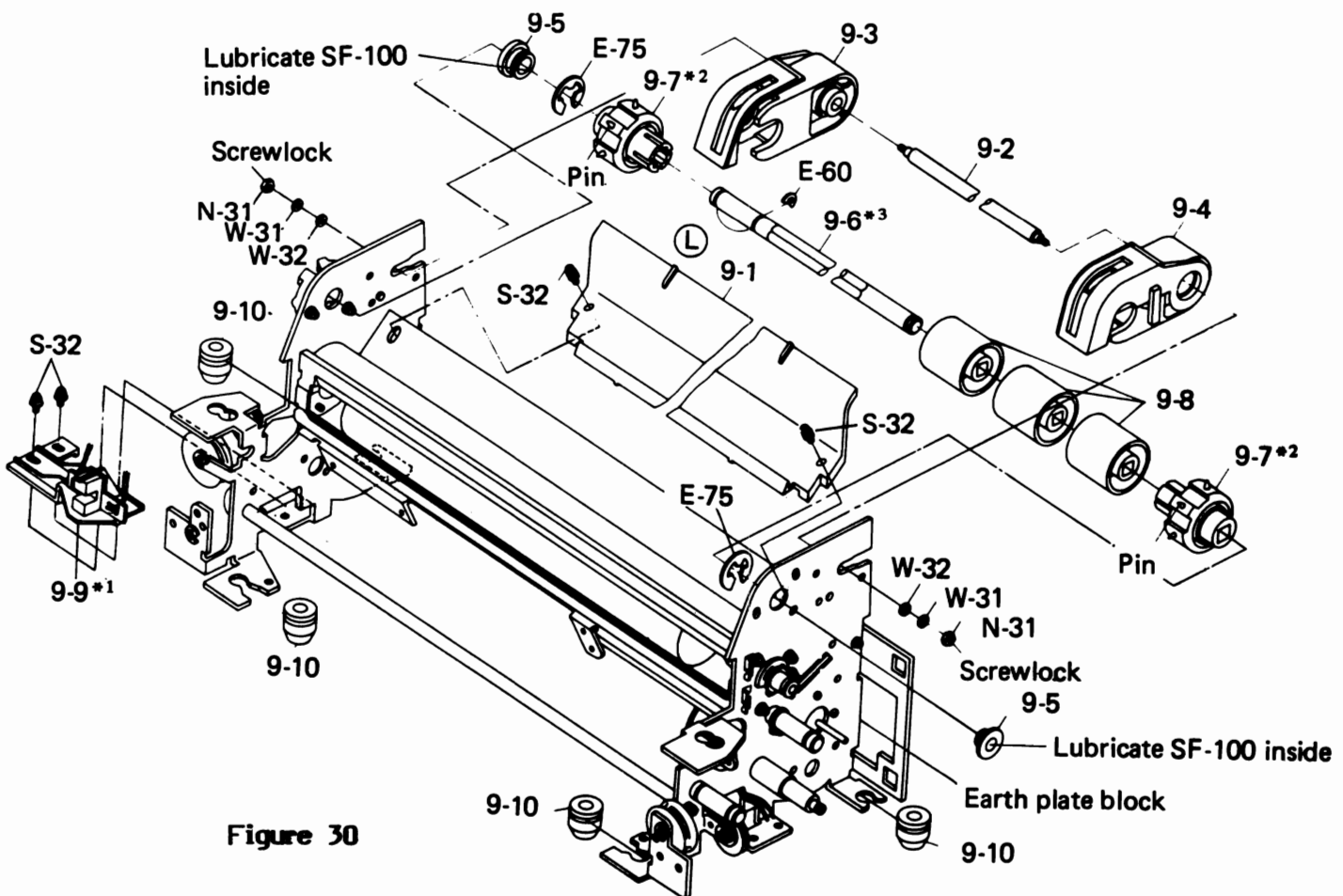
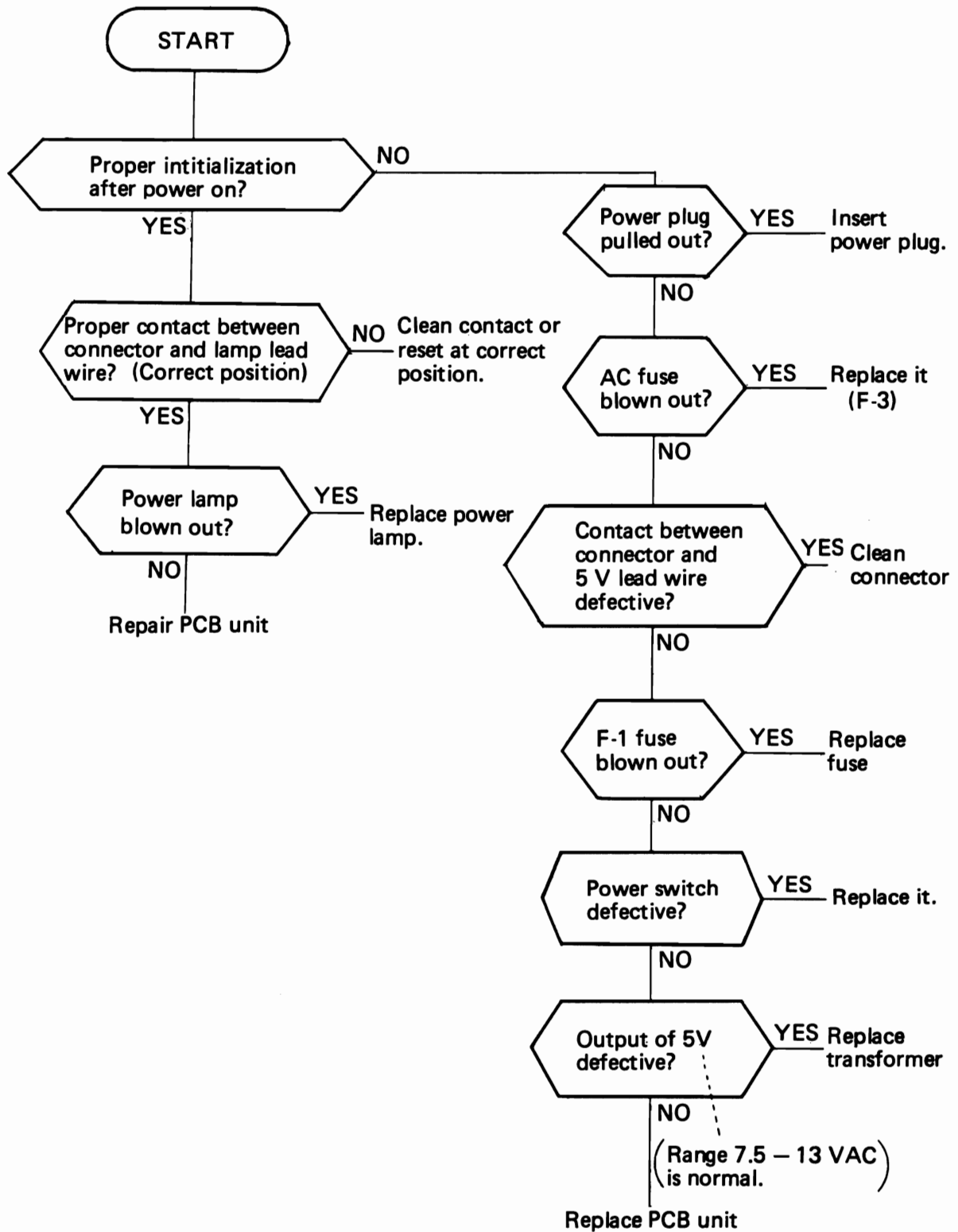

Figure 30

VII. TROUBLESHOOTING

1. The power lamp does not light



2. No initialization

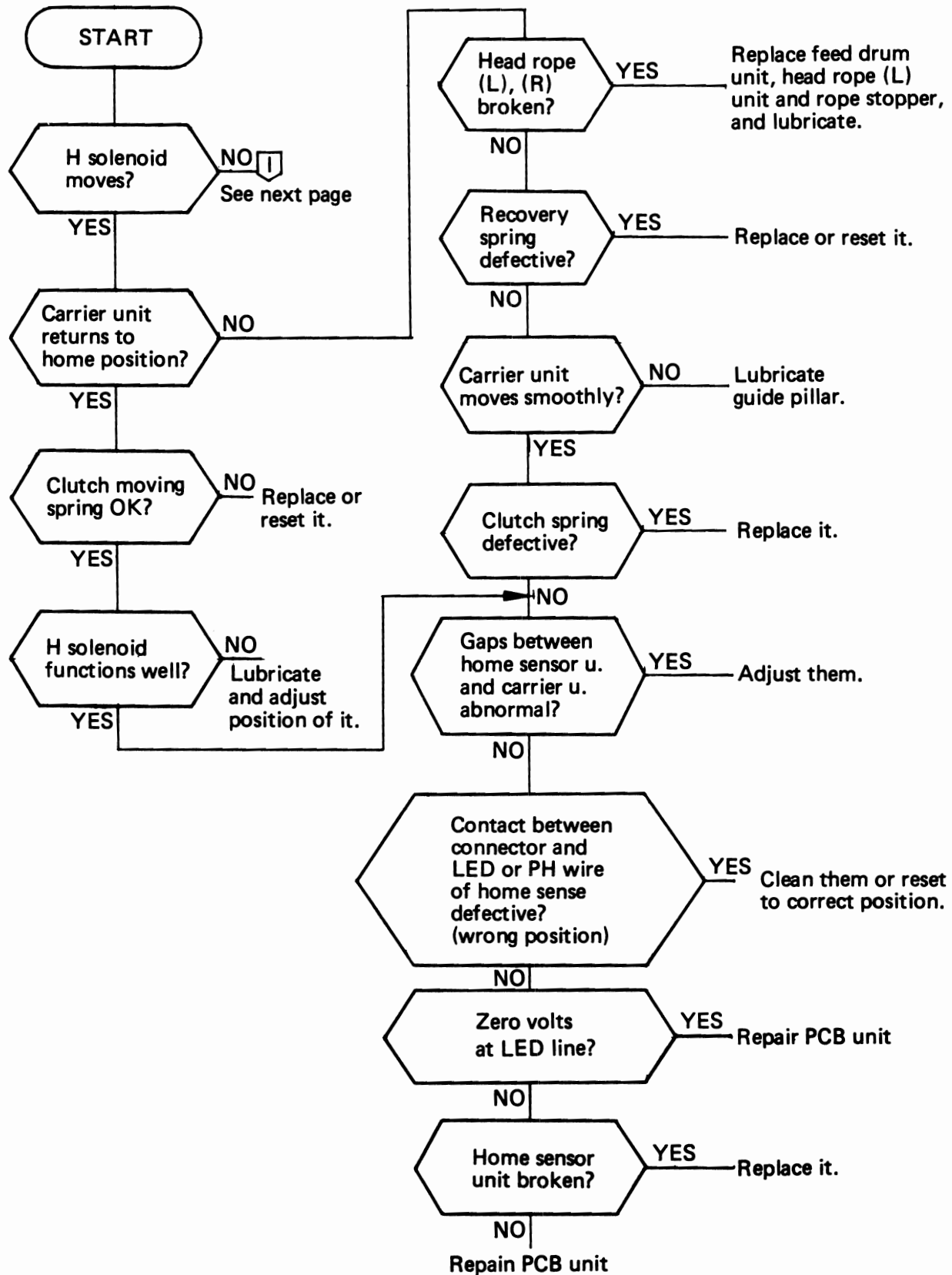

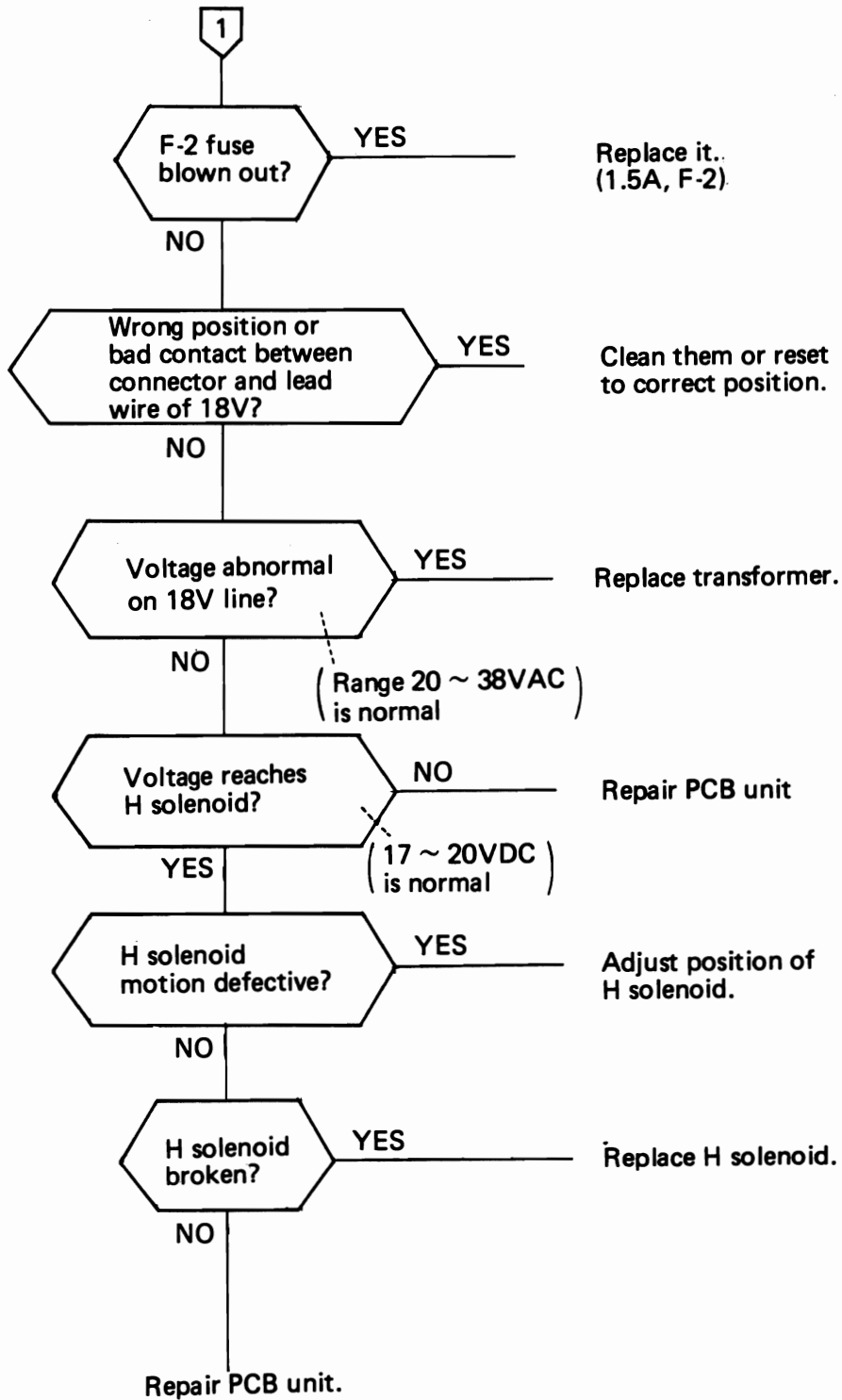

3. The carrier unit does not move with a print command.

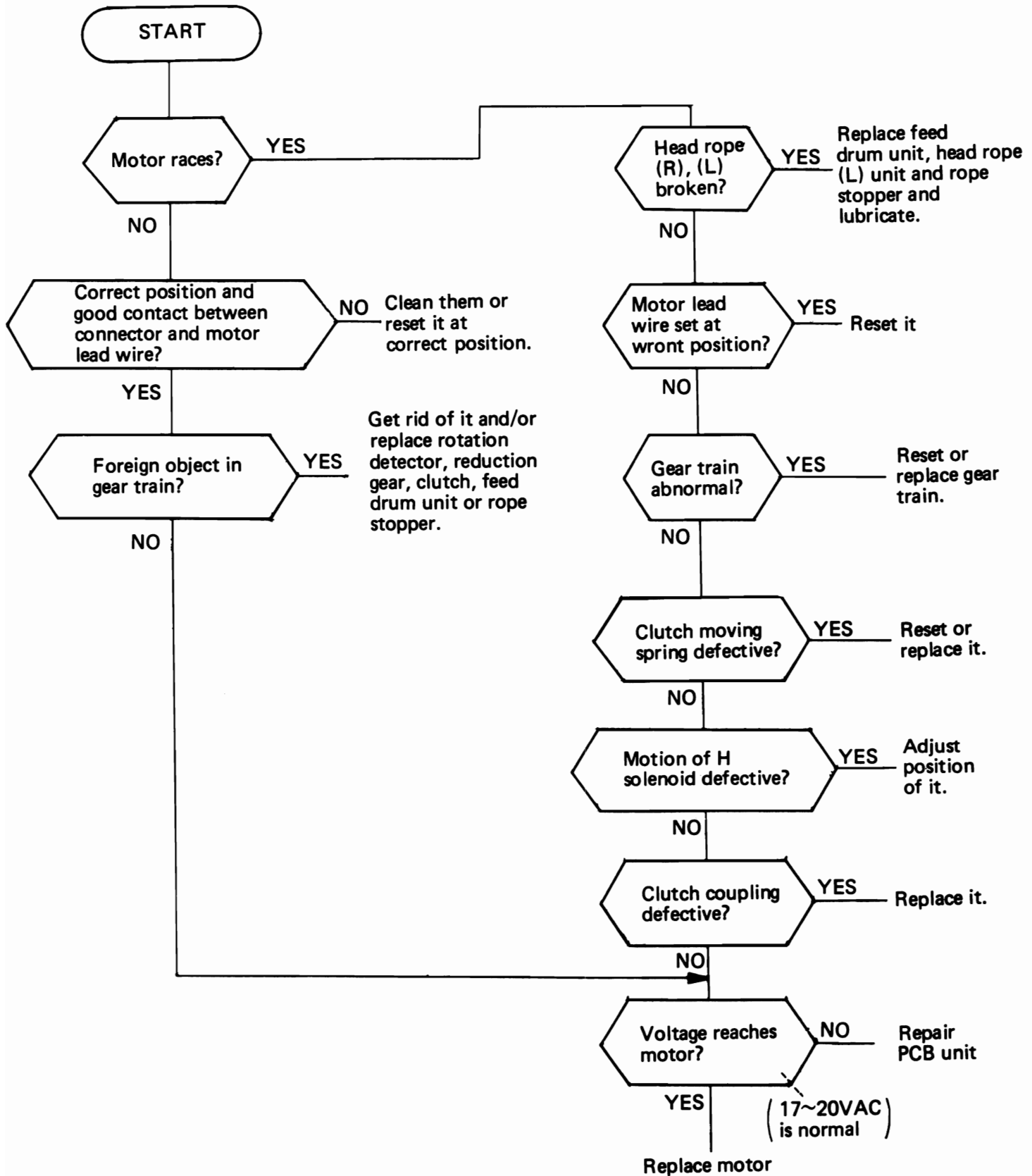

4. The carrier unit overruns

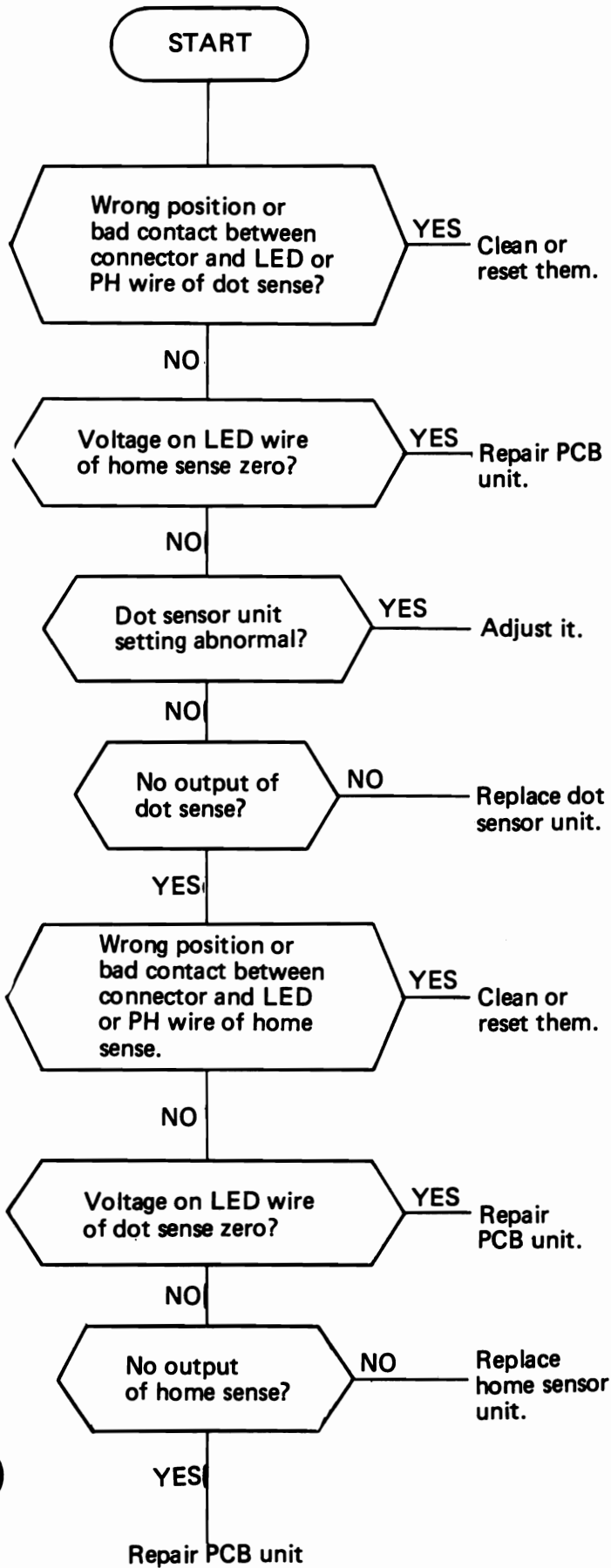

5. Improper paper feed movement

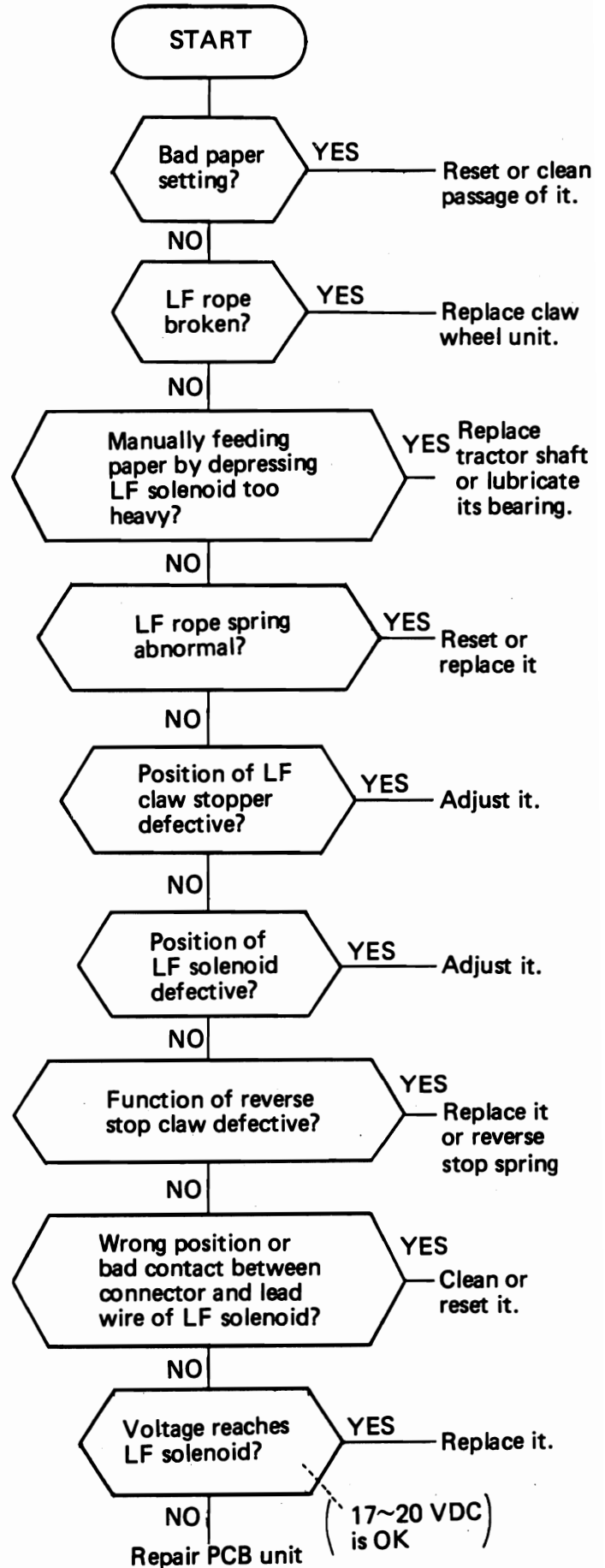

6. No printing or poor print quality

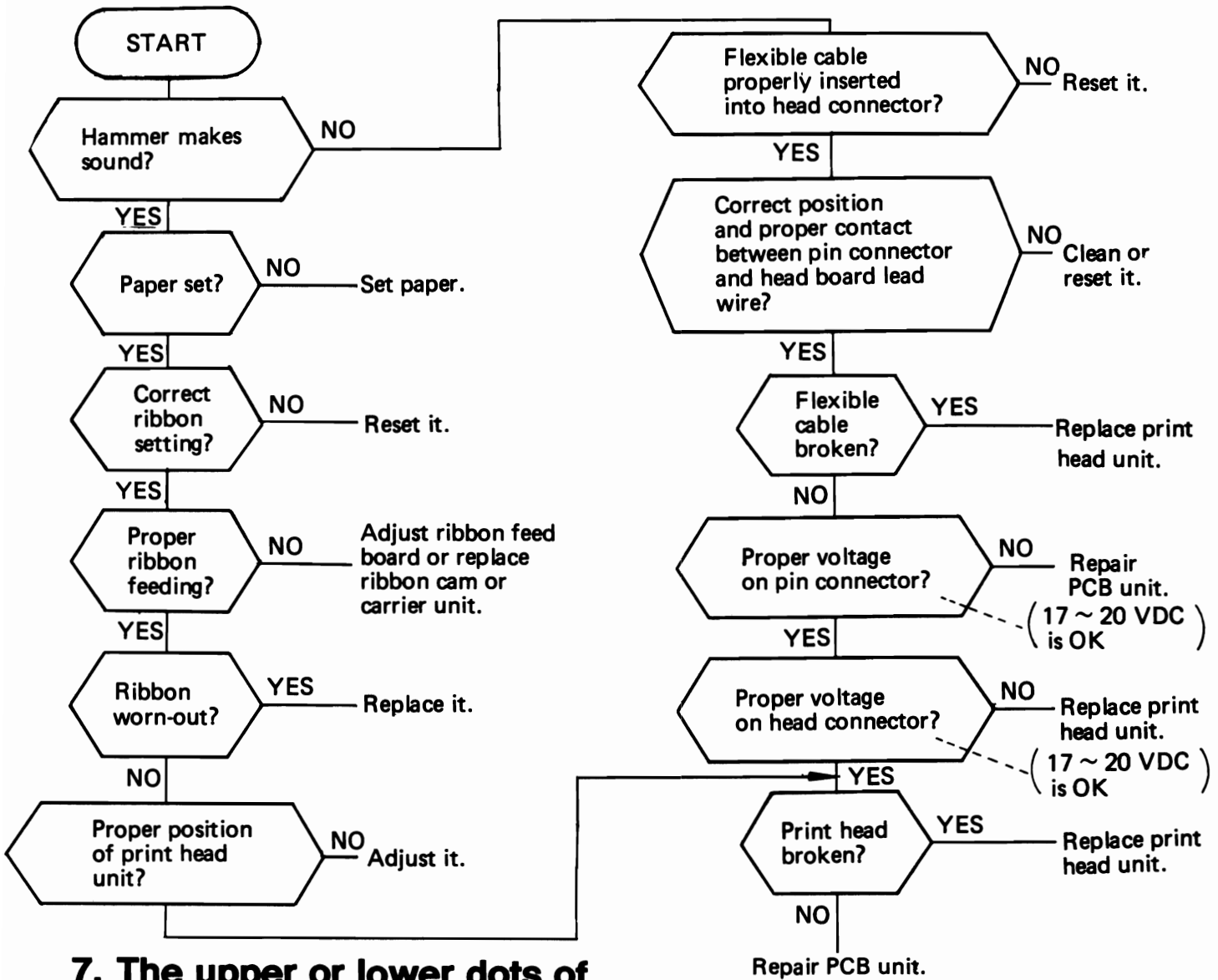

7. The upper or lower dots of printed characters are missing.

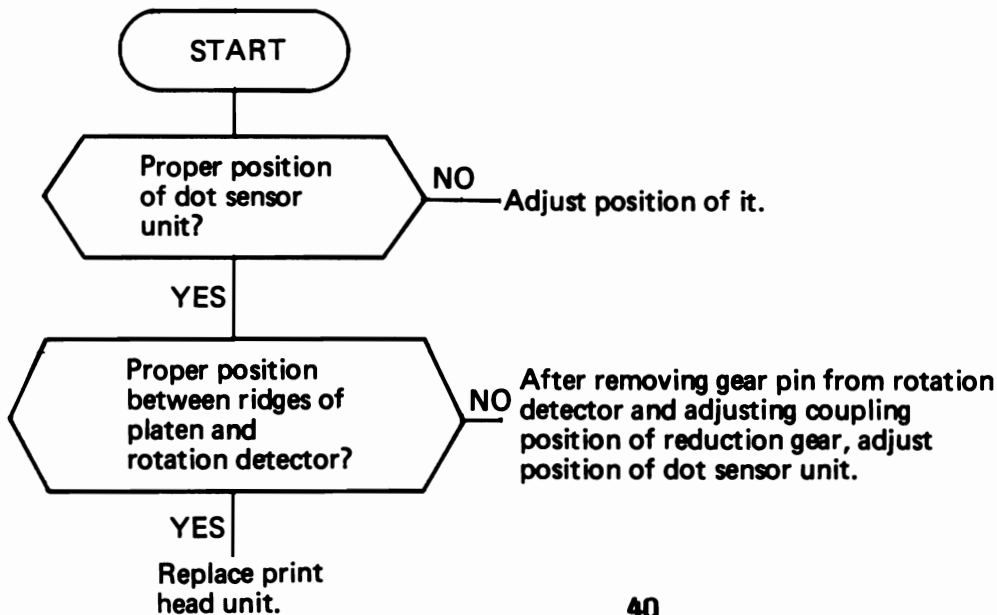

8. The upper and lower dots of printed characters are too light.

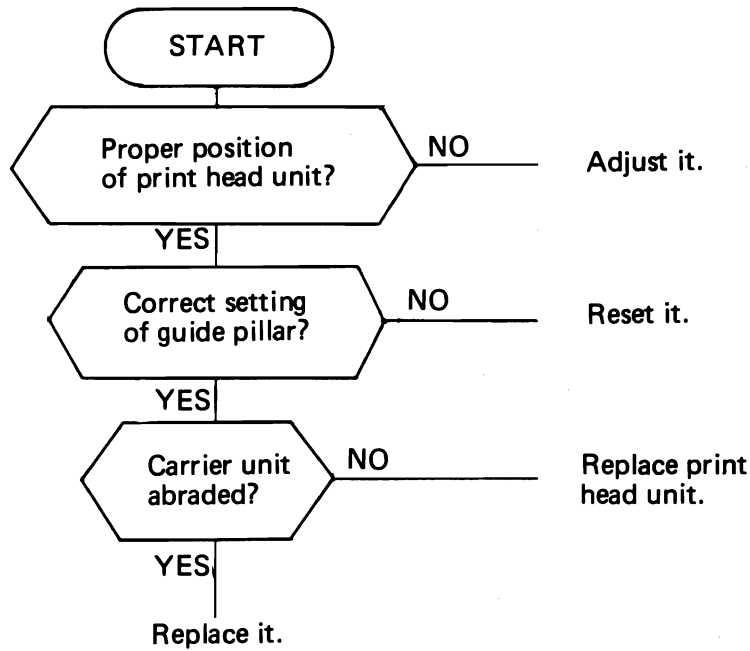

9. Printings are too light.

Refer to "6. No printing or poor print quality."

10. Smudging by ribbon.

